

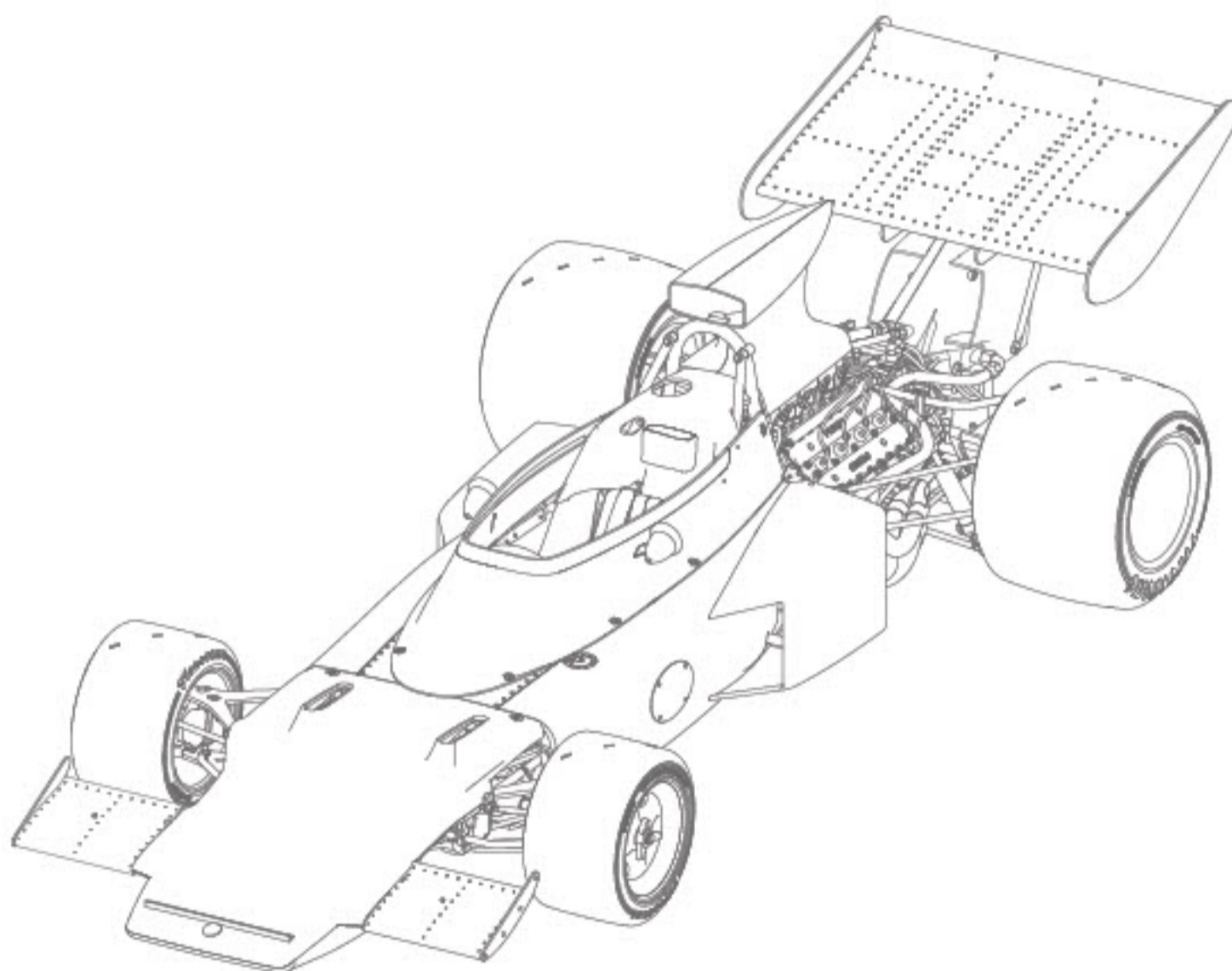

# Pocher<sup>®</sup>

1:8 Model Kits



**Lotus 72D – 1972 British GP – Emerson Fittipaldi  
Assembly Manual**



CLASSIC  
TEAM LOTUS



**GB**

The Lotus 72 is seen by many to be the most beautiful, innovative, and iconic Formula One racing car of the 1970s. Colin Chapman's revolutionary idea of moving the radiator from the front of the car to a pair in sidepods allowed a sweeping change in the looks, handling and ability of Formula One cars. Firstly, in Gold Leaf colours and then in the stunning black and gold of JPS, the Lotus 72 swept all before it in the early 1970s, proving to be the class of the field. Powered by a just as legendary engine - the Ford Cosworth DFV 3.0 V8 - the Lotus mated the power of this world beating engine with handling that left the rest of the field behind. This chassis - identity number 7 (of 10) - was raced at the 1972 British Grand Prix by the soon to be World Champion Emerson Fittipaldi. Around the sweeping confines of the Brands Hatch Grand Prix circuit Emerson emerged victorious over the Tyrrell of Jackie Stewart by just 4 seconds as he charged towards that year's crown. This amazing Pocher model features a detailed chassis with the detail continuing through the suspension and engine components to the incredibly detailed cockpit. All logos are faithfully recreated and with real rubber tyres this impressive 1:8 model will become the star of any collection of motorsport heroes, famous cars, or pieces of art. Study drawings and practice assembly before cementing parts together. Detailed scale model for adult collector. The colors and contents may vary from illustration.

**I**

Molti considerano la Lotus 72 una delle più belle, innovative ed iconiche vetture di Formula 1 degli anni '70. L'idea rivoluzionaria di Colin Chapman di eliminare il radiatore dalla parte anteriore della vettura e di sistemare due radiatori sui lati ha rappresentato un cambiamento radicale nell'aspetto, nella manovrabilità e nelle prestazioni delle vetture di Formula 1. Inizialmente con i colori di Gold Leaf e poi nello splendido colore nero ed oro di JPS, la Lotus 72 ha spazzato via tutti i rivali agli inizi degli anni '70 dimostrando di essere una vettura d'eccezionale qualità nel settore. Dotata di un motore leggendario - il Ford Cosworth DFV 3.0 V8 - la Lotus ha coniugato la potenza di questo motore senza rivali al mondo con una manovrabilità che le ha permesso di lasciarsi alle spalle la concorrenza in pista. Questo telaio - numero d'identificazione 7 (di 10) - ha gareggiato nel Gran Premio di Gran Bretagna del 1972 con alla guida Emerson Fittipaldi, futuro Campione del mondo. Lungo i vasti confini del circuito Brands Hatch sede del Gran Premio, Emerson ha conquistato la vittoria battendo la Tyrrell di Jackie Stewart di soli 4 secondi, avanzando verso la conquista del campionato di quell'anno. Questo fantastico modellino Pocher presenta un telaio molto dettagliato, componenti delle sospensioni e del motore altrettanto dettagliati ed un cockpit incredibilmente realistico. Tutti i loghi sono stati ricreati fedelmente e con i pneumatici in vera gomma, questo fantastico modellino in scala 1:8 diventerà la star di ogni collezione di "eroi" dell'automobilismo, vetture famose, o opere d'arte.

**D**

Der Lotus 72 wird von vielen als der schönste, innovativste und legendärste Formel-1-Rennwagen der 1970er Jahre angesehen. Grundlegend war Colin Chapmans revolutionäre Idee, den Kühler von der Vorderseite des Wagens auf ein Paar Seitenkästen zu verlegen. Diese Erneuerung führte zu einem radikalen Wandel in Design, Handling und Fahreigenschaften der Formel-1-Boliden. Zuerst in der Gold Leaf Version und dann im atemberaubenden Schwarz und Gold der JPS („John-Player-Special“-)Ausführung, stellte der Lotus 72 in den frühen 1970er Jahren die gesamte Konkurrenz in den Schatten. Er war schlicht eine Klasse für sich. Dazu kam ein nicht minder legendärer Motor - der Ford Cosworth DFV 3.0 V8. Der Lotus kombinierte die Power des erfolgreichsten Motors aller Zeiten mit einem Handling, das seine Gegner alt aussehen ließ. Das Monocoque mit der Identitätsnummer 7 (von 10) wurde 1972 beim Großen Preis von Großbritannien vom späteren Weltmeister Emerson Fittipaldi gesteuert. Auf der weitläufigen Rennstrecke des Brands Hatch Grand Prix siegte Emerson auf dem Weg zum Weltmeistertitel mit gerade 4 Sekunden Vorsprung vor dem Tyrrell des Briten Jackie Stewart. Das Chassis dieses faszinierenden Pocher Modell-Bausatzes ist in allen Einzelheiten reproduziert. Das Fahrgestell setzt sich über die Aufhängungs- und Motorkomponenten bis hin zum unglaublich detaillierten Cockpit fort. Alle Logos sind originalgetreu nachgebildet. Mit seinen echten Gummireifen wird dieses beeindruckende 1:8 Modell zum Prunkstück jeder Sammlung von Motorsporthelden, berühmten Autos oder Kunstwerken.

**F**

La Lotus 72 est considérée par beaucoup comme la plus belle, la plus innovante et la plus emblématique des voitures de course de Formule 1 des années 1970. L'idée révolutionnaire de Colin Chapman de déplacer les radiateurs du nez de la voiture dans des pontons latéraux a permis d'opérer un changement radical dans l'apparence, la maniabilité et les performances des voitures de Formule 1. D'abord sous les couleurs Gold Leaf, puis dans la superbe livrée noir et or de JPS, la Lotus 72 a tout balayé sur son passage au début des années 1970 et démontré qu'elle était incontestablement la meilleure. Propulsée par un moteur tout aussi légendaire - le Ford Cosworth DFV 3.0 V8 - la Lotus associait la puissance de ce moteur de renommée mondiale à une maniabilité qui lui permettait le reste du peloton derrière elle. Ce châssis numéro 7 (sur 10) a été piloté lors du Grand Prix de Grande-Bretagne de 1972 par Emerson Fittipaldi, qui allait bientôt devenir champion du monde. Sur le circuit du Grand Prix de Brands Hatch, Fittipaldi a remporté la victoire sur la Tyrrell de Jackie Stewart avec seulement 4 secondes d'avance, le rapprochant ainsi du titre de champion du monde cette année-là. Cette splendide maquette Pocher présente un châssis extrêmement détaillé jusqu'à la suspension et aux composants du moteur. Le poste de pilotage affiche lui aussi un niveau de détail exceptionnel. Tous les logos sont fidèlement recréés et, avec de vrais pneus en caoutchouc, cette maquette remarquable à l'échelle 1:8 deviendra la vedette de toute collection de héros du sport automobile, de voitures célèbres ou d'œuvres d'art.

**E**

Muchas personas consideran el Lotus 72 como el bólido de Fórmula 1 más hermoso, innovador y emblemático de la década de 1970. La revolucionaria idea de Colin Chapman de trasladar el radiador del frontal del coche a los pontones supuso un cambio radical en la estética, la conducción y las prestaciones de los coches de Fórmula 1. Primero en los colores de Gold Leaf y, después, en los impactantes negro y dorado de JPS, el Lotus 72 arrasó a comienzos de los 70 y demostró pertenecer a una clase aparte. Impulsado por un motor igualmente legendaria, el Ford Cosworth DFV 3.0 V8, el Lotus combinaba la potencia de este motor sin rival con una capacidad de manejo capaz de dejar atrás a todos sus competidores. Este chasis, con numeración 7 (de 10), fue pilotado en el Gran Premio de Gran Bretaña de 1972 por Emerson Fittipaldi, que no tardaría en convertirse en campeón del mundo. En el restringido trazado del circuito Brands Hatch, Emerson se alzó con la victoria sobre el Tyrrell de Jackie Stewart por solo 4 segundos, en su avance imparable hacia la corona de ese año. Este fantástico modelo Pocher destaca por su detallado chasis, suspensión y componentes del motor, culminando en el increíble nivel de detalle del puesto del conductor. Todos los logotipos se han recreado fielmente y, con sus neumáticos de goma auténtica, este impresionante modelo 1:8 será la estrella de cualquier colección de héroes del automovilismo, coches famosos u obras de arte.

**日本**

ロータス72は、1970年代で最も美しく、革新的かつ象徴的なF1レーシングカーとして、多くの人に愛されています。ラジエーターをフロントからサイドポッド内に移すというコリン・チャップマンの画期的なアイデアにより、F1マシンの外観、ハンドリング、性能を一変させることができました。1970年代初頭のロータス72は、それまでのゴールドリーフカラーから漆黒にゴールドのJPSカラーに塗り替えられ、F1史上最も美しいマシンと評価されました。伝説のフォード・コスワースDFV3.0 V8エンジンを搭載したロータスは、世界最先端のエンジンのパワーと、F1マシン最高のハンドリングで他を圧倒しました。IDナンバー7 (10台中7台目) が付けられたこのシャシーは、1972年のイギリスGPで間もなく世界チャンピオンとなるエマーソン・フィッティパルディがドライブしました。高低差が非常に激しいブランズハッチGPサーキットで、エマーソンはジャッキー・スチュワートが運転するティレルに4秒差を付けて勝利し、この年の王座に就きました。この素晴らしいPOCHER (ポケール) の模型車は、サスペンション、エンジン部品から極めて精巧に再現されたコックピットに至るまで、見事なディテールのシャシーが特徴です。ロゴもすべて忠実に再現されており、本物のゴム製タイヤを履いたこの印象的なスケール1/8の模型車は、モータースポーツヒーローや名車、そして芸術作品のコレクションにおける、主役となることでしょう。



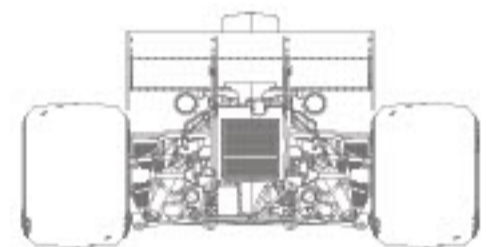
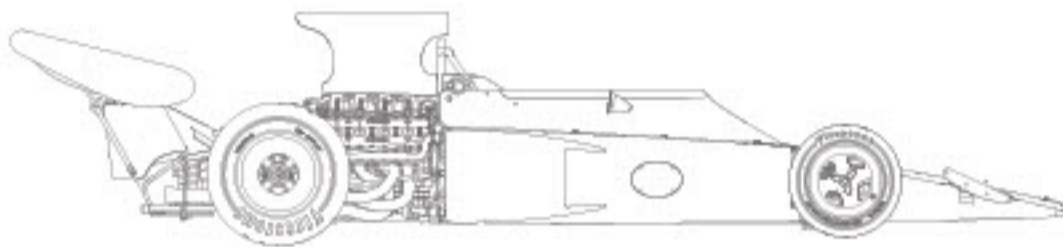
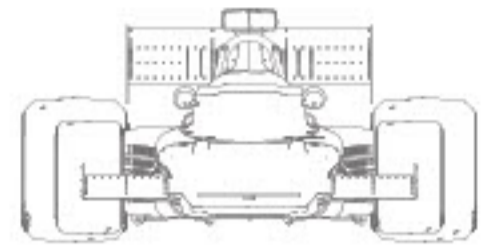
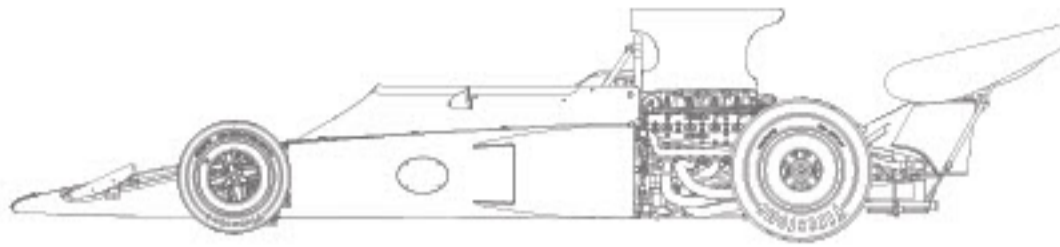

Assembly icon instructions

Assembly phase  
Fase di montaggio  
Montagephase  
Phase de montage  
Fase de montaje  
カテゴリーごとの組み立て



Assembled group  
Gruppo assemblato  
Versammelten gruppe  
Groupo assemblé  
Groupo montado  
組み立てたグループ



Pay attention  
Prestare attenzione  
Achtung  
Attention  
Prestar atención  
注意



Cable  
Cavo  
Kabel  
Câble  
Cable  
ケーブル



Cement  
Incollare  
Kleben  
Coller  
Pegar  
接着



Assembly order  
Ordine de montaggio  
Die Ordnung der montage  
Ordre d'assemblage  
Orden de montaje  
組み付け順



Sprue part number  
Número del pezzo  
Sprue Teilenummer  
Número de pièce  
Número de pieza  
部品番号

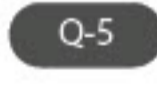

Water decal  
Decalcomanie  
Decals  
Decalcomanies  
Calcomnia  
デカール



Screwed  
Avvitare  
Festschrauben  
Visser  
Atornillar  
ビス



Cement  
Incollare  
Kleben  
Coller  
Pegar  
接着



1.5 x 4 PM

HK-MSPP-M015-004-003



1.5 x 4 PB

HK-TRSP-P015-004-003



1.5 x 4 PWB

HK-TRSP-PW-M015-004-003



1.5 x 3 PWM

HK-MSPPW-M015-003-005



1.5 x 5 PM

HK-MSPP-M015-005-003



1.5 x 7 PM

HK-MSPP-M015-007-003



1.5 x 3 PM

HK-MSPP-M015-003-003



1.7 x 10 PM

HK-MSPP-M017-010-005



2 x 4 PB

HK-TRSP-P-M020-004-004



2 x 4 PWM

HK-MSPPW-M020-004-005



2 x 5 PM

HK-MSPP-M020-005-004



M6 x 35mm

HK-MSA-M050-035-010

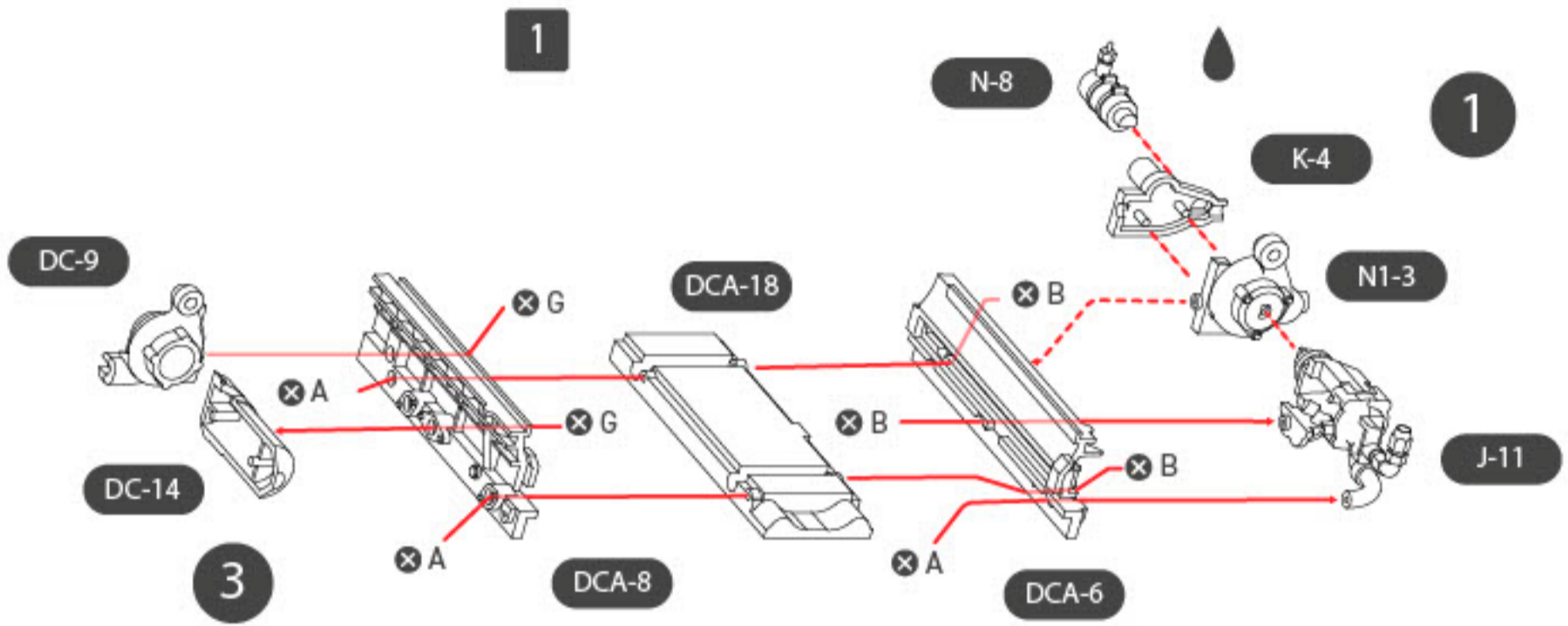

2

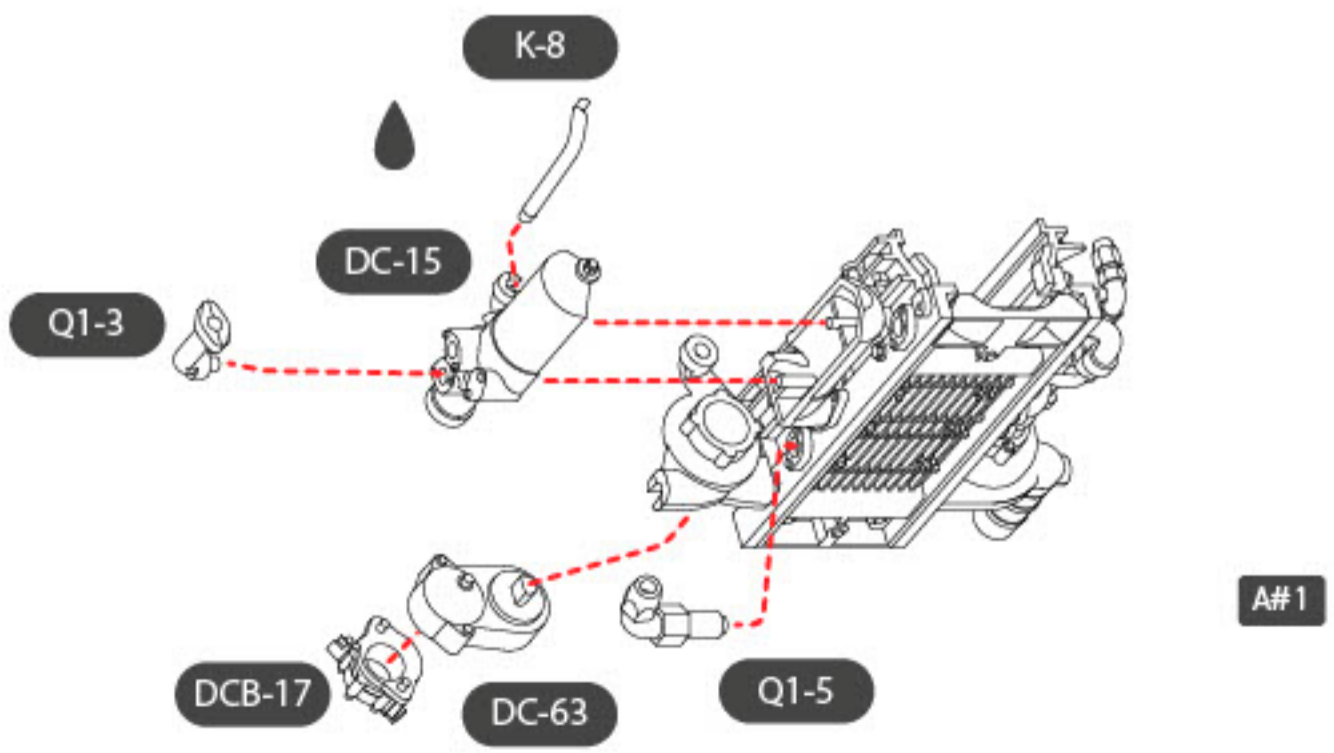

SCREW A = 3  
 SCREW B = 3  
 SCREW G = 2

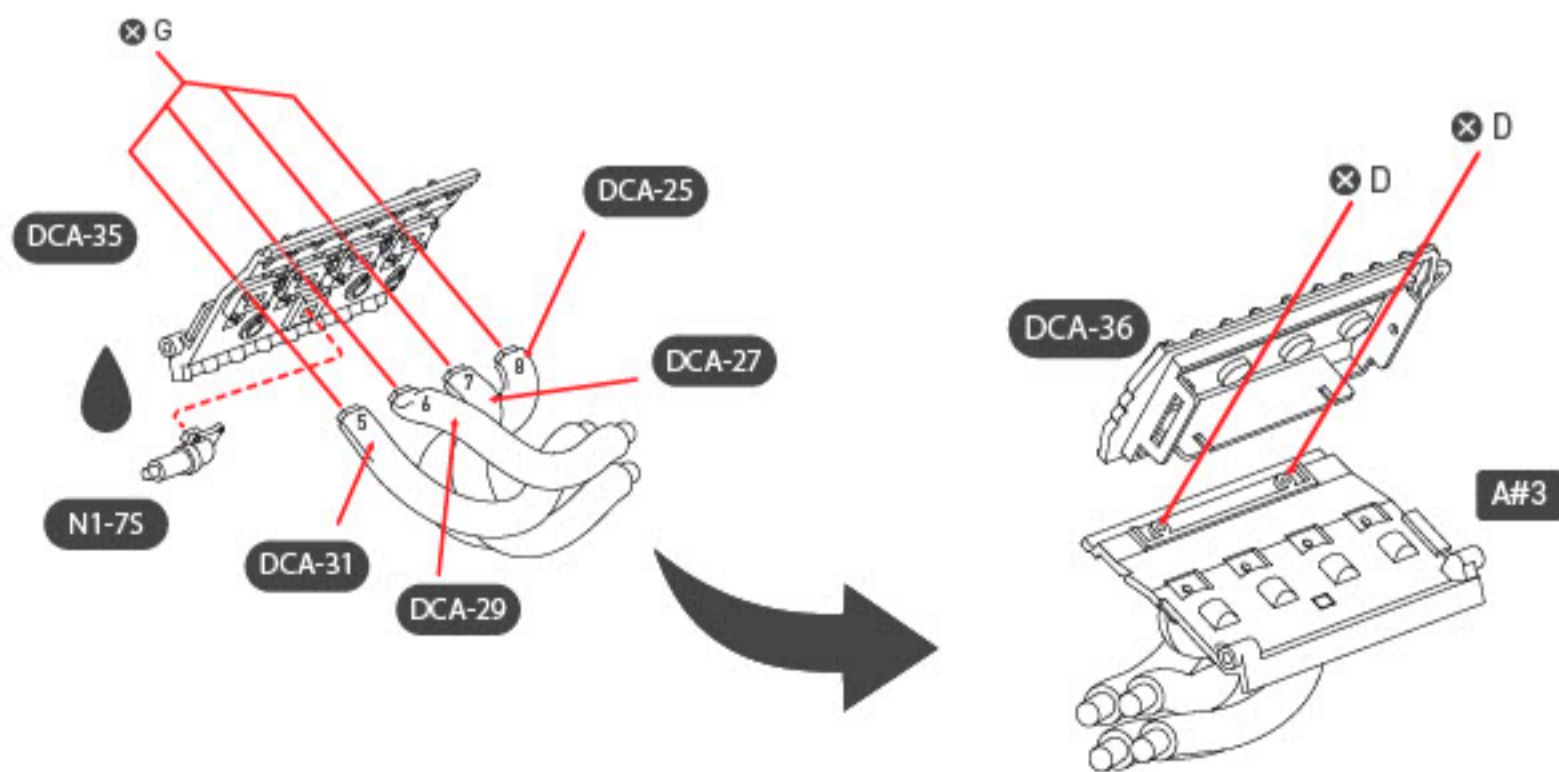
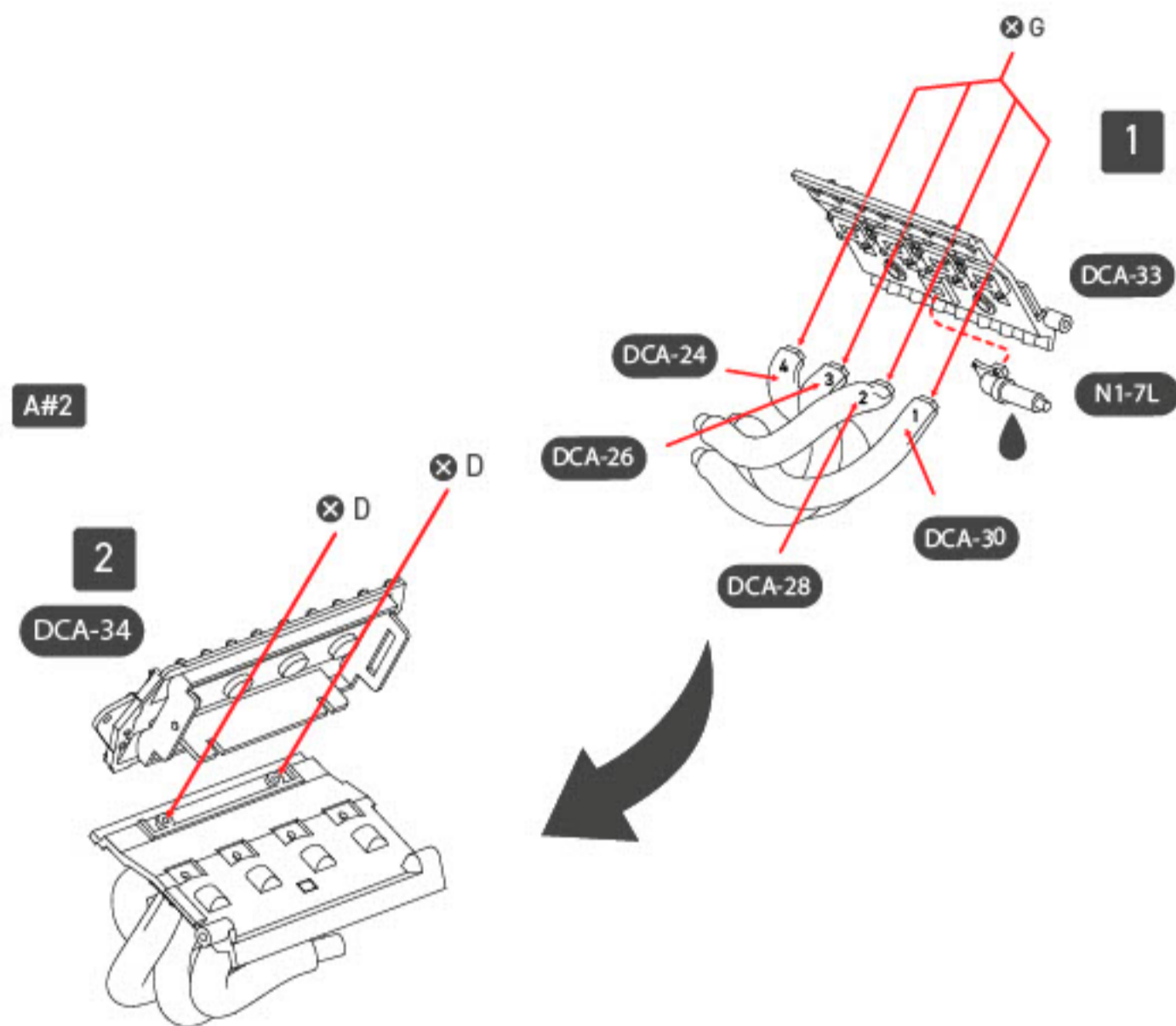

SCREW D = 4  
SCREW G = 8





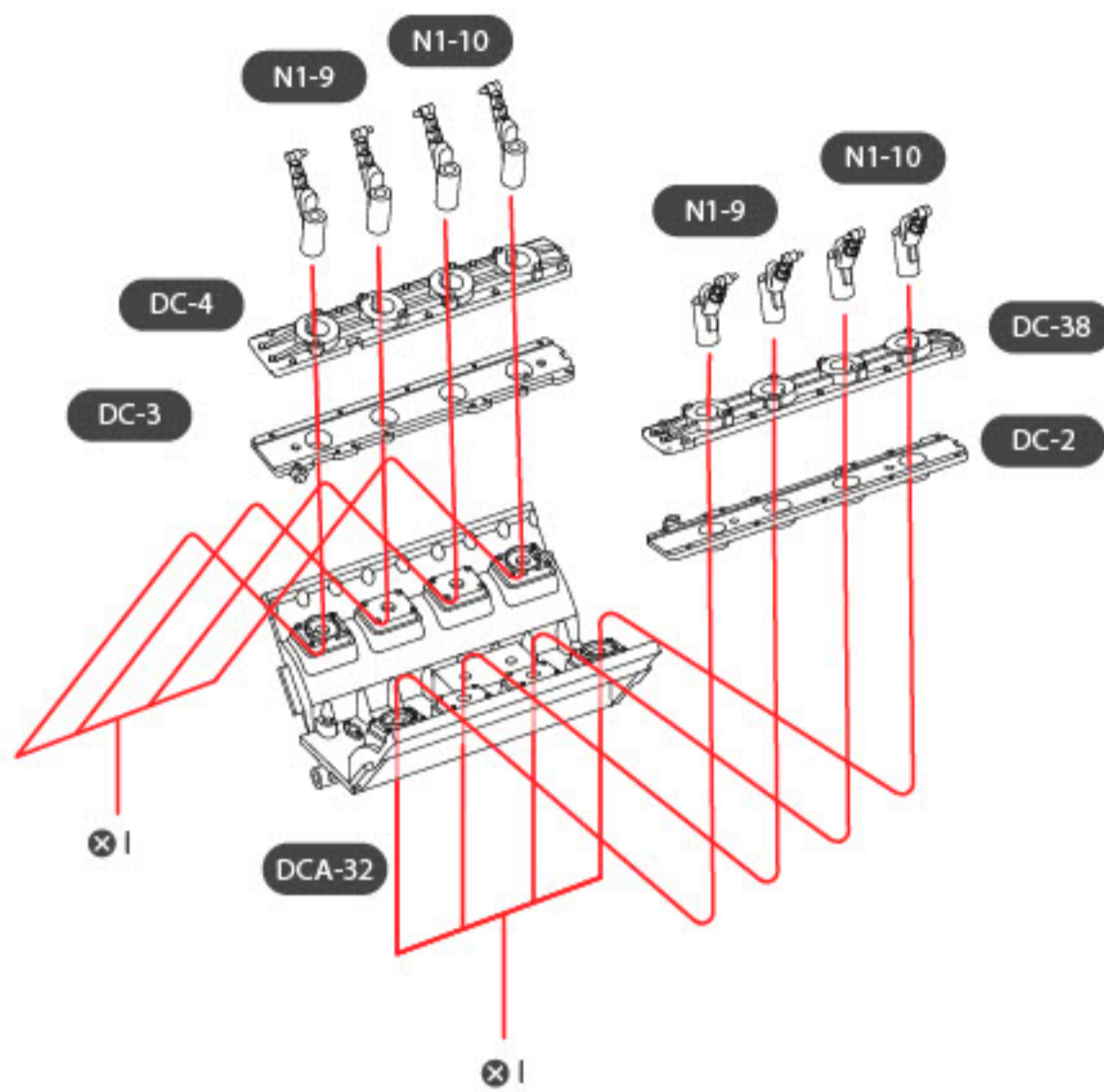

A#5

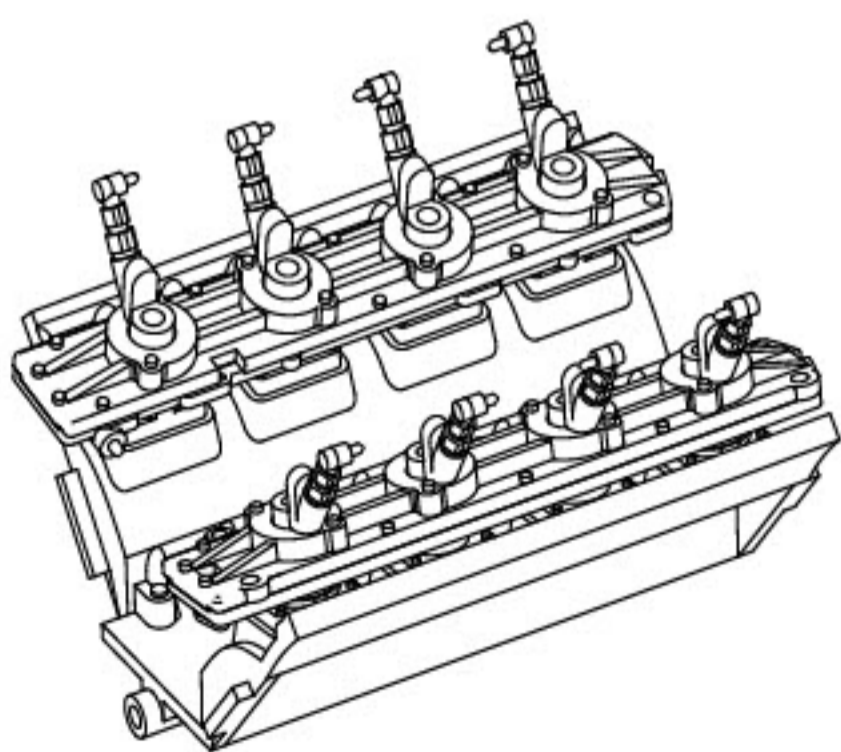

SCREW I = 8

A#4

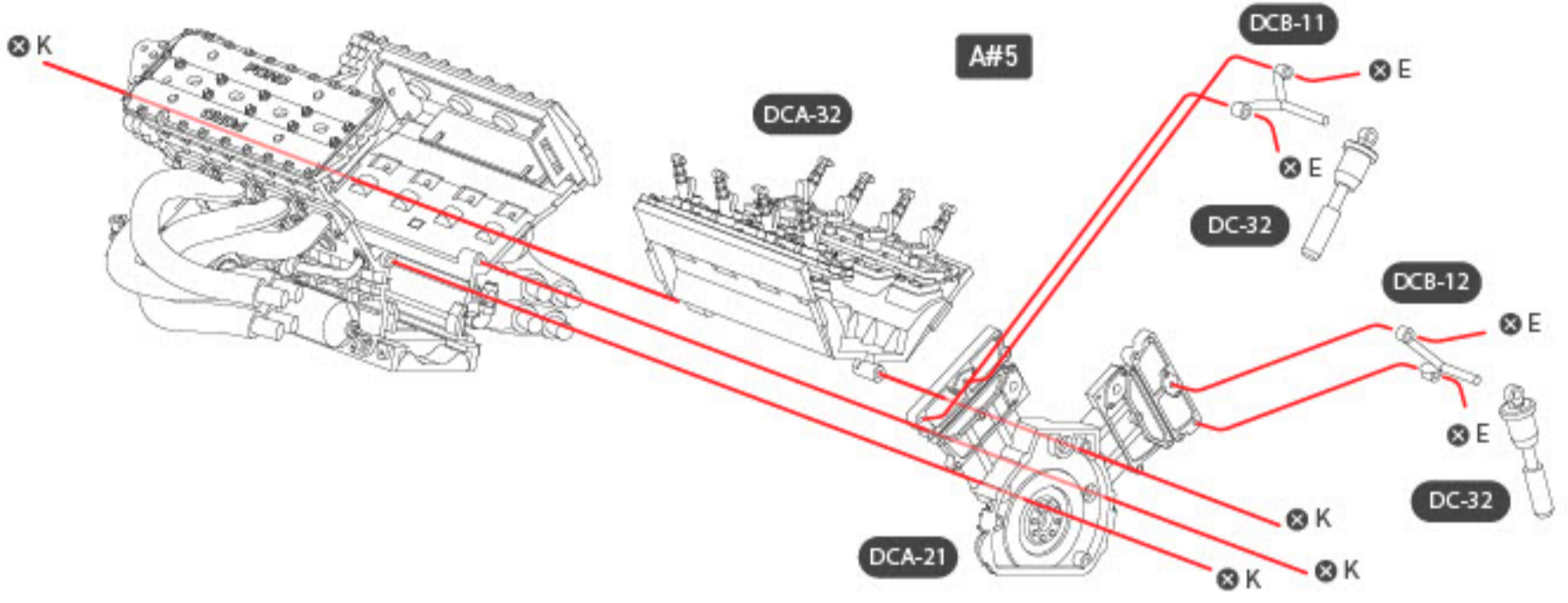

A#6

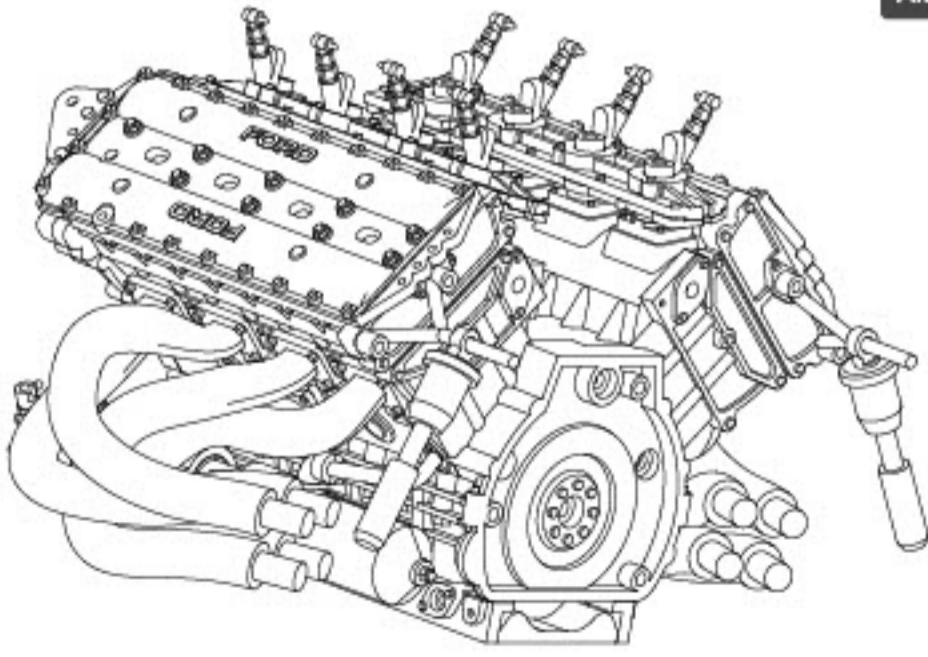

SCREW E = 5  
SCREW K = 4



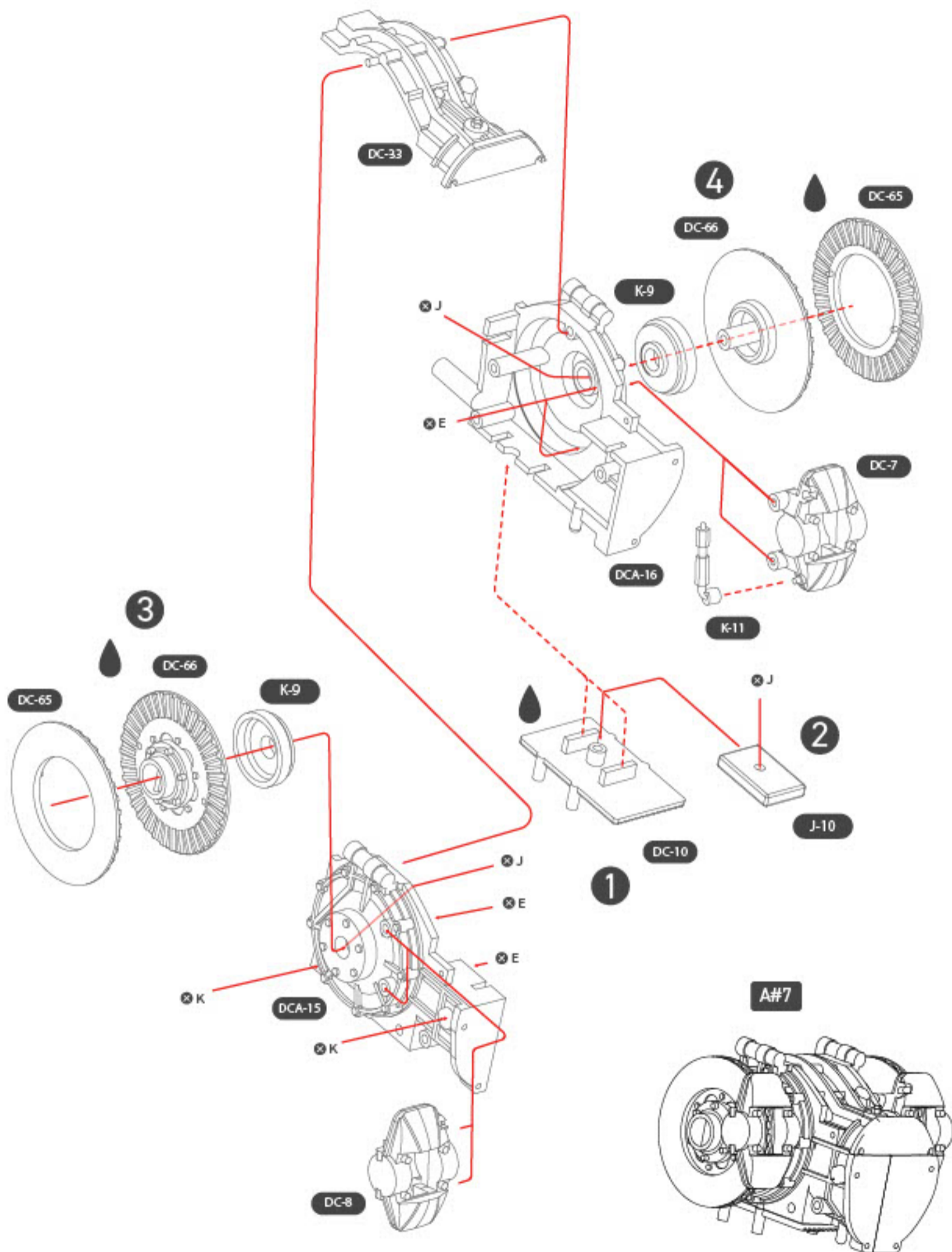

SCREW E = 4  
 SCREW J = 3  
 SCREW K = 2

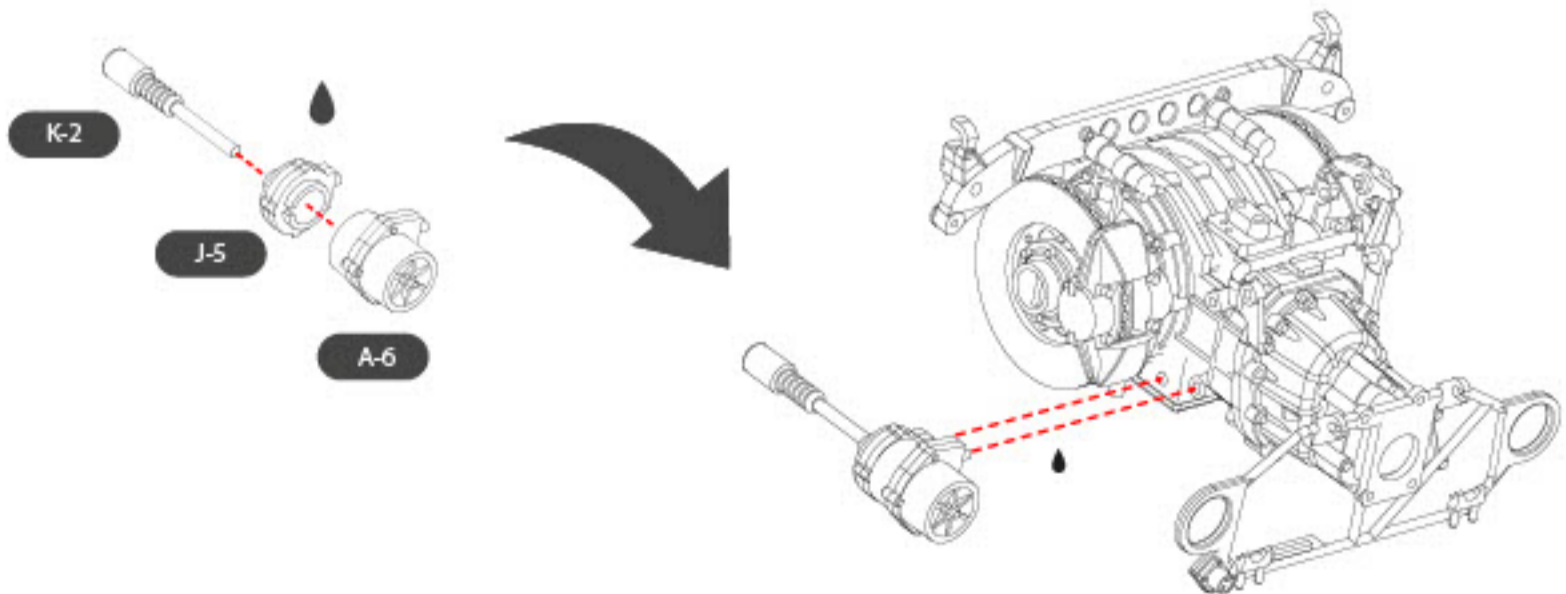
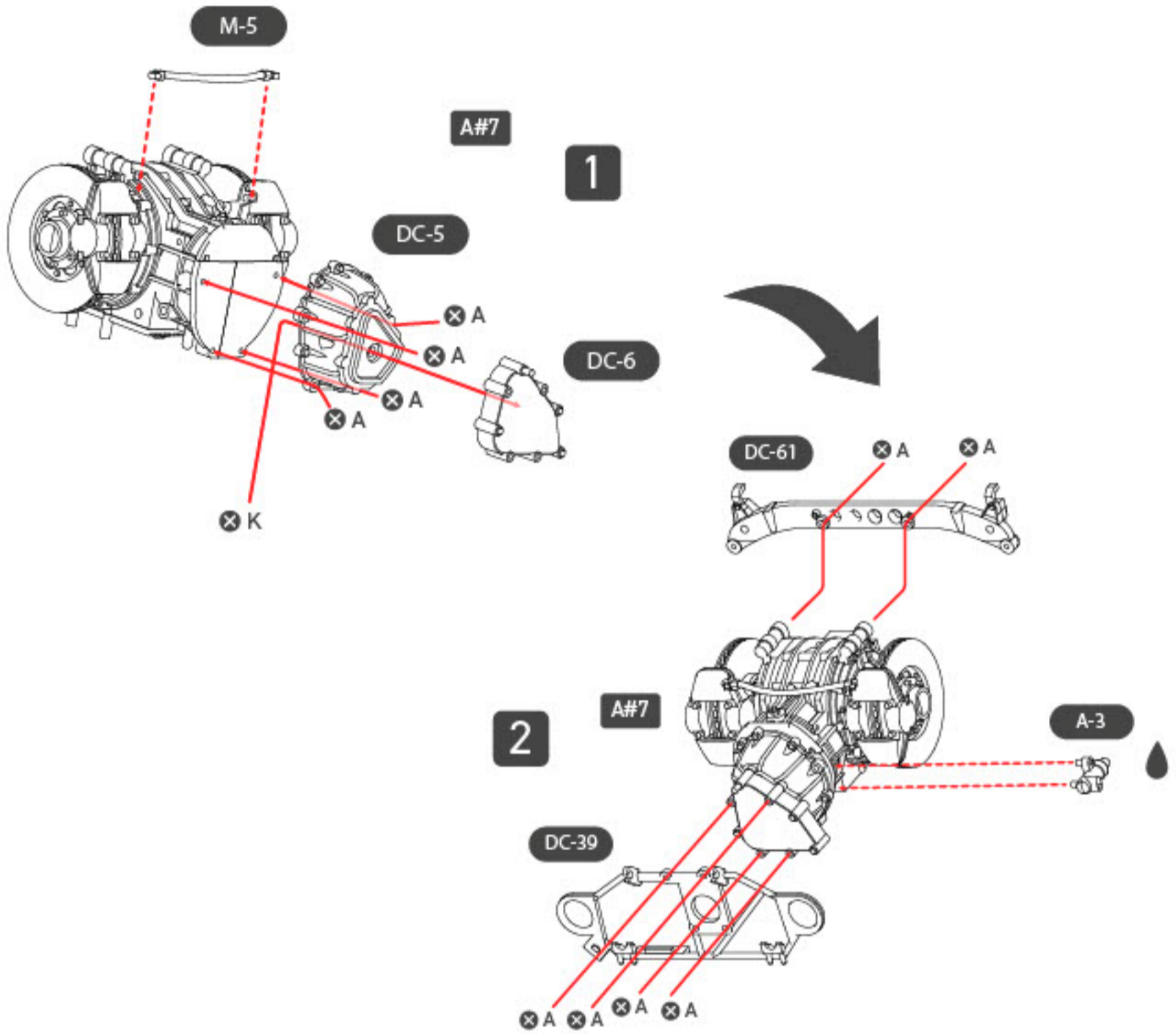

SCREW A = 8  
 SCREW B = 2  
 SCREW K = 1

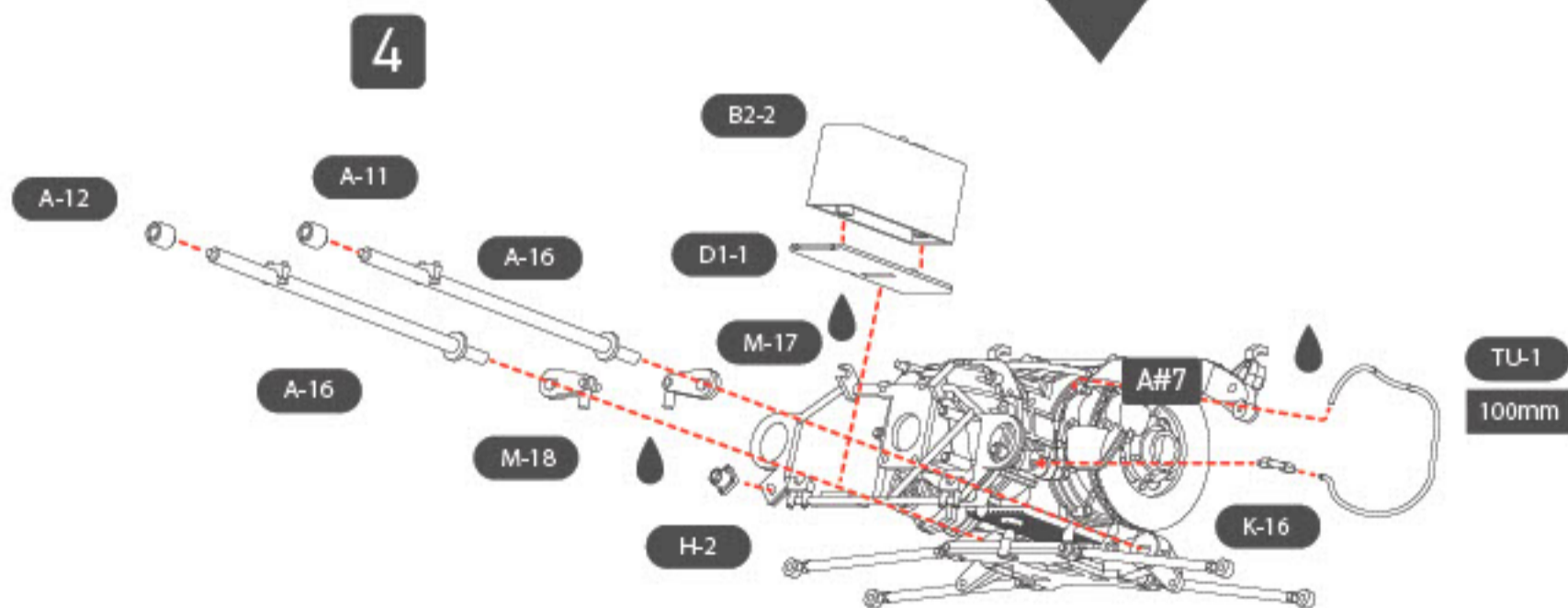
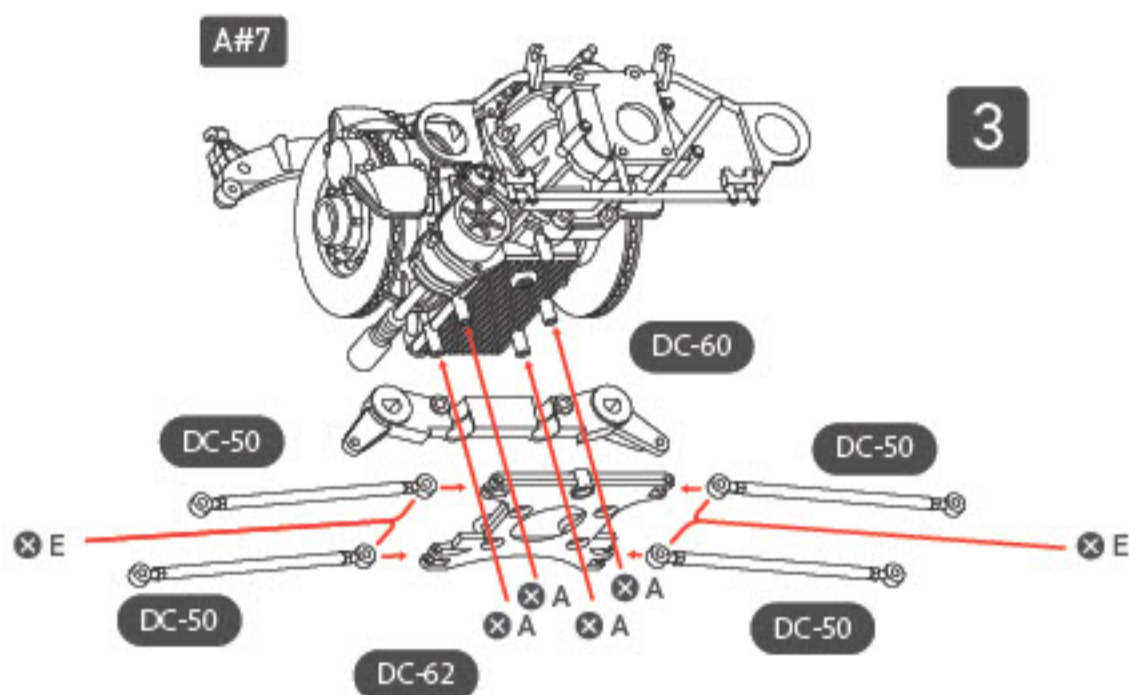

SCREW A = 4  
SCREW E = 4



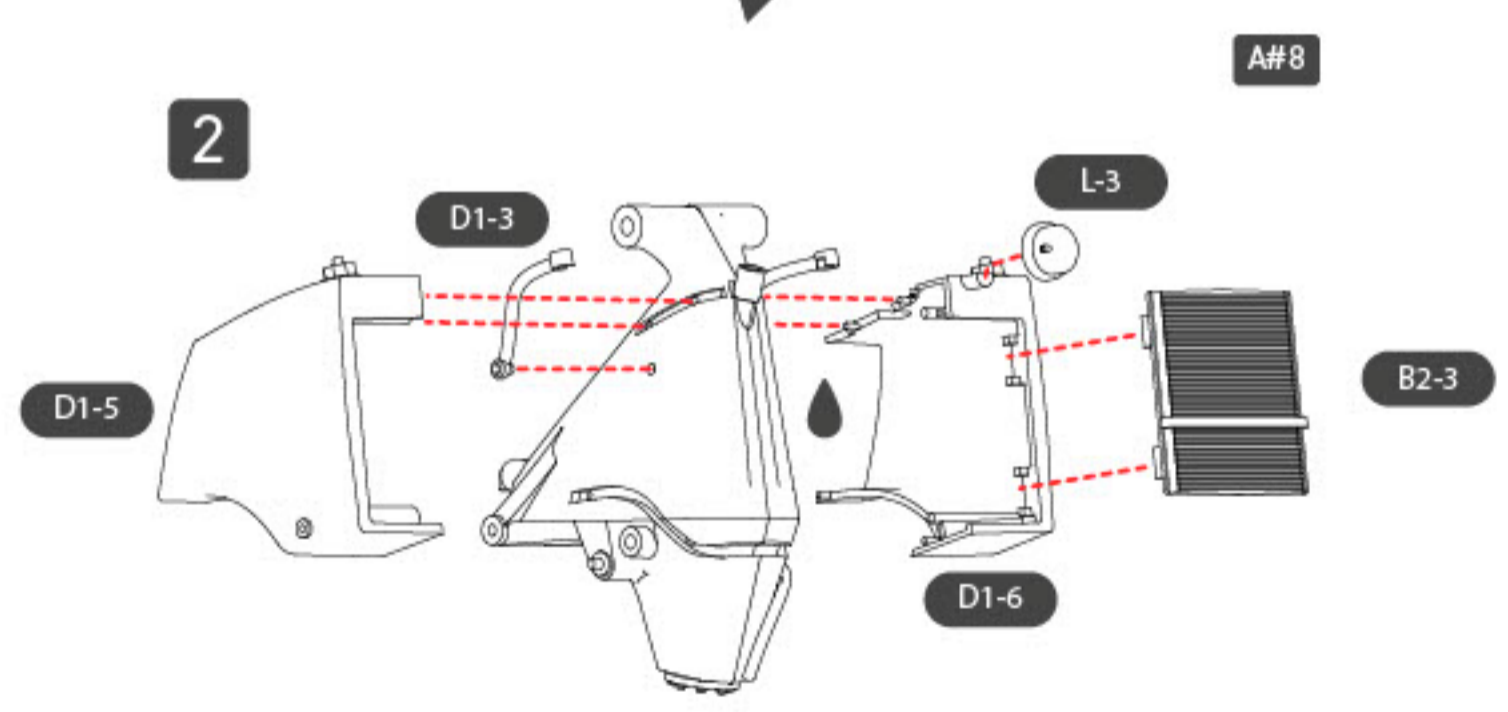
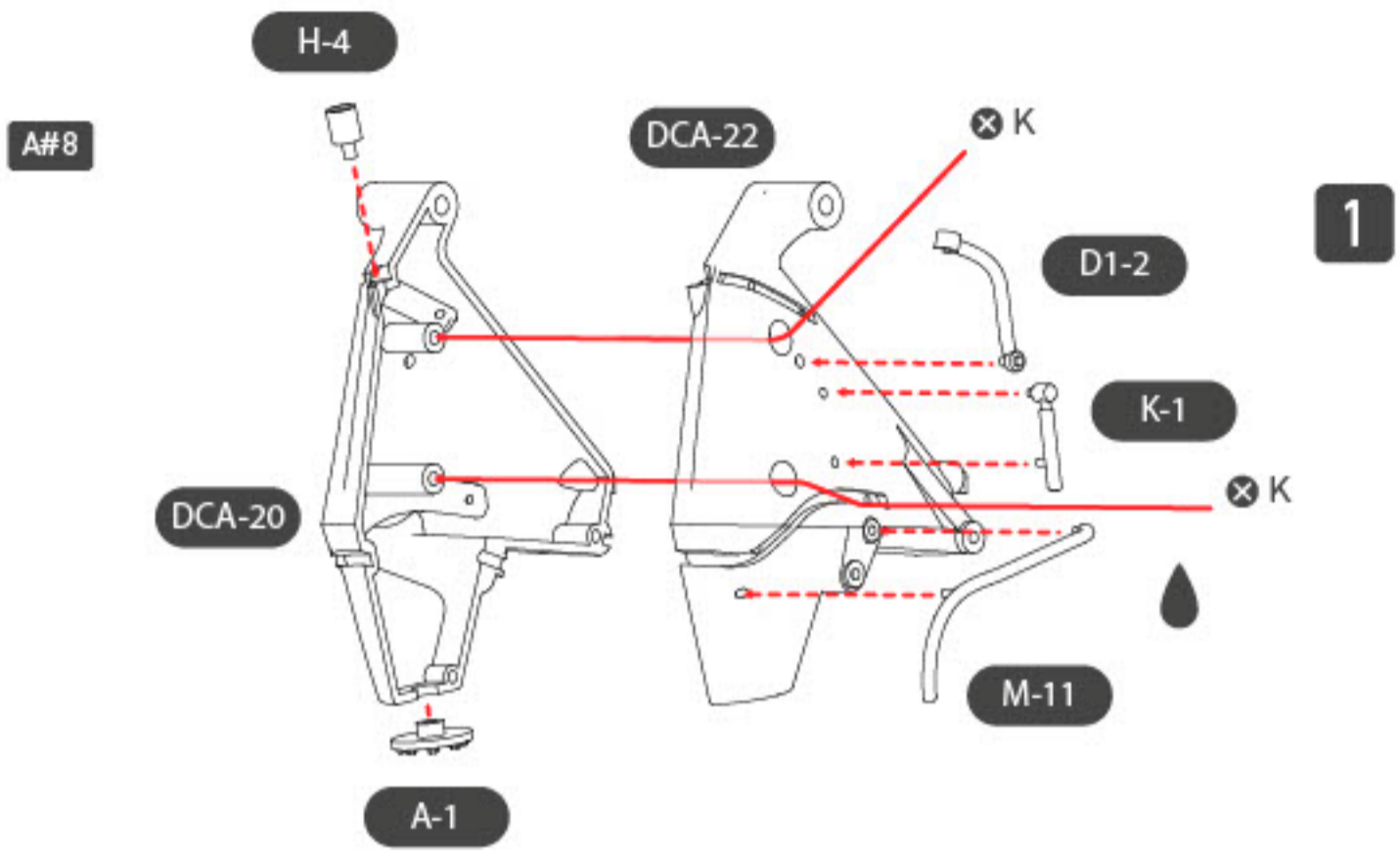

SCREW K = 2

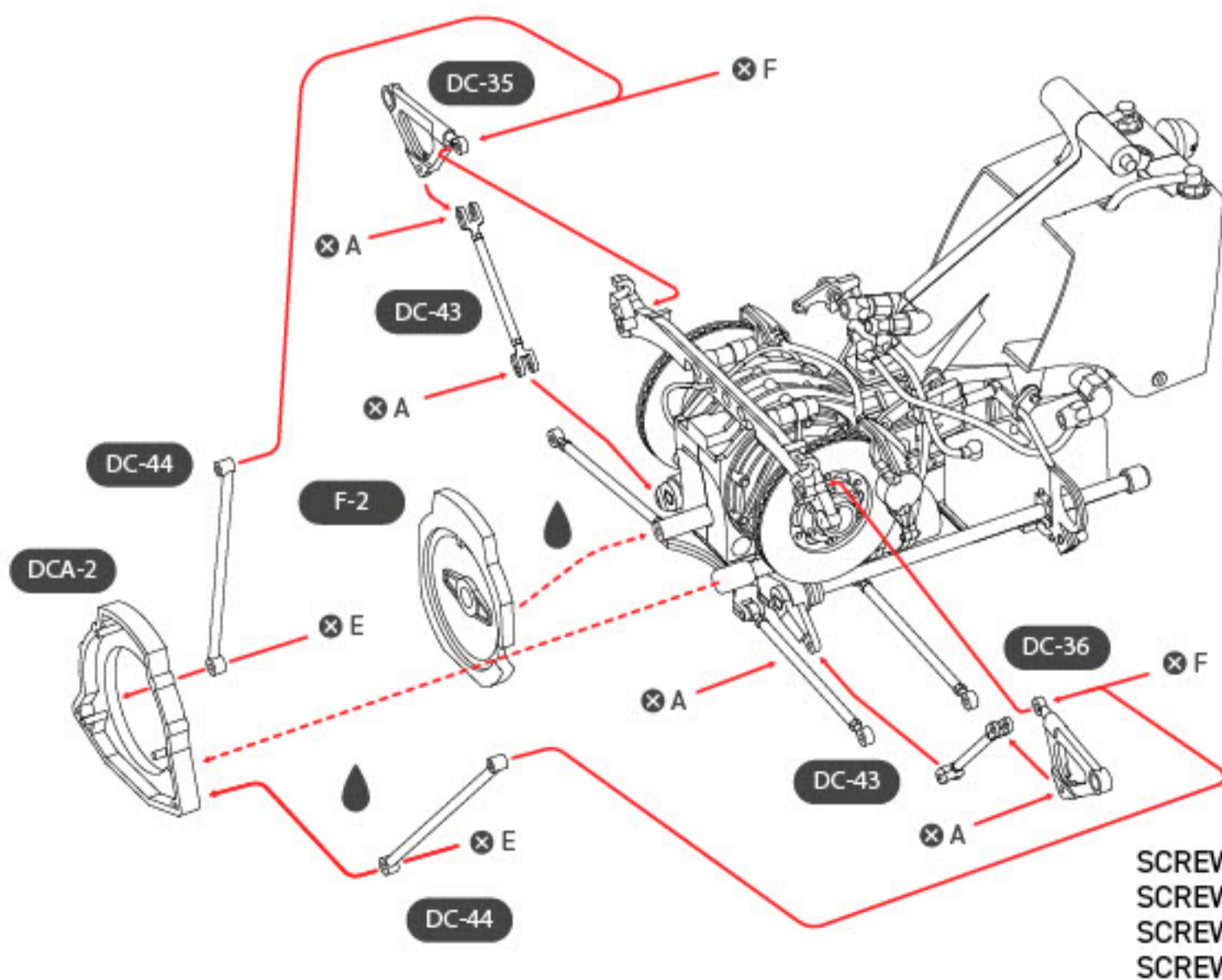
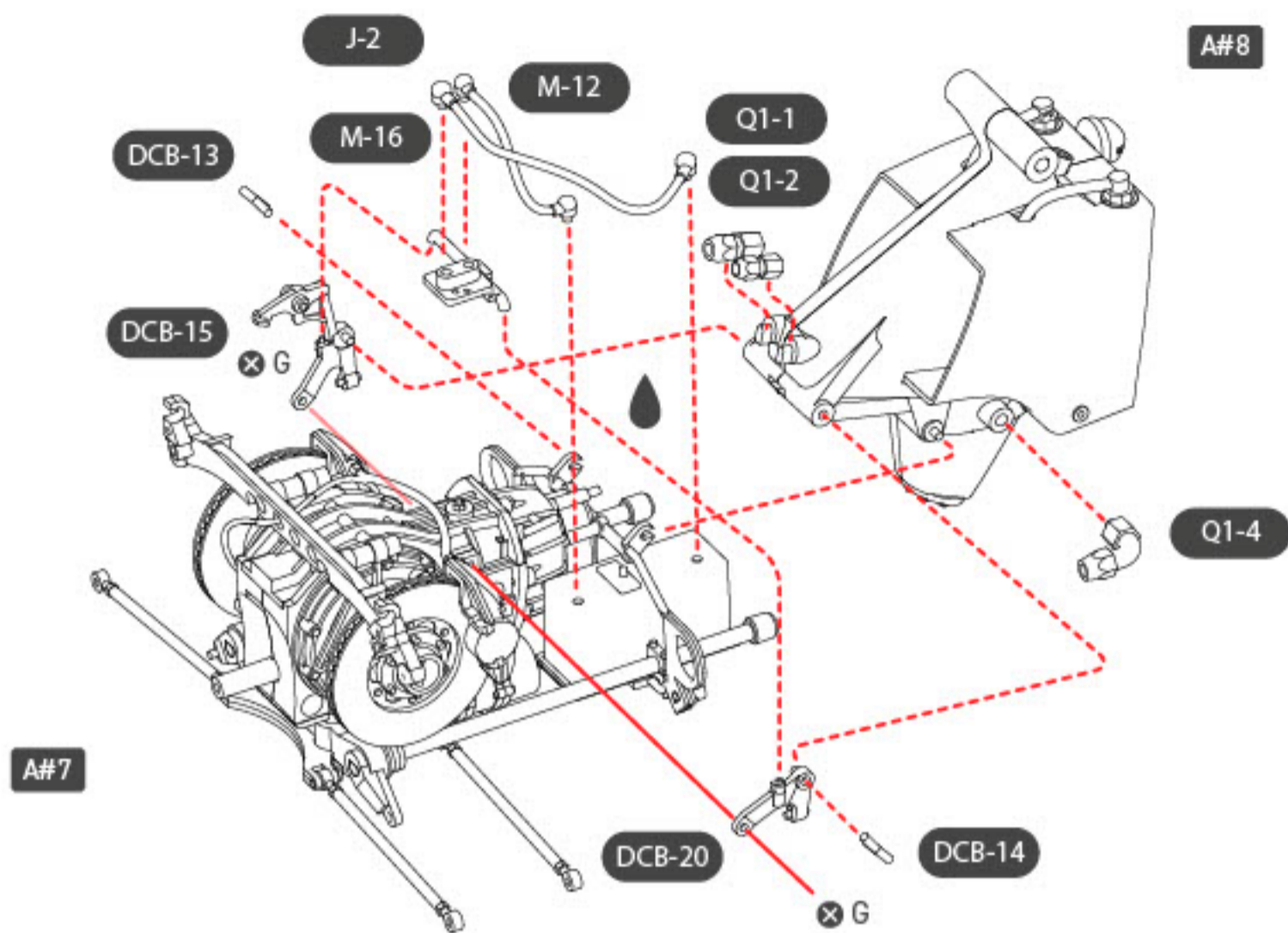

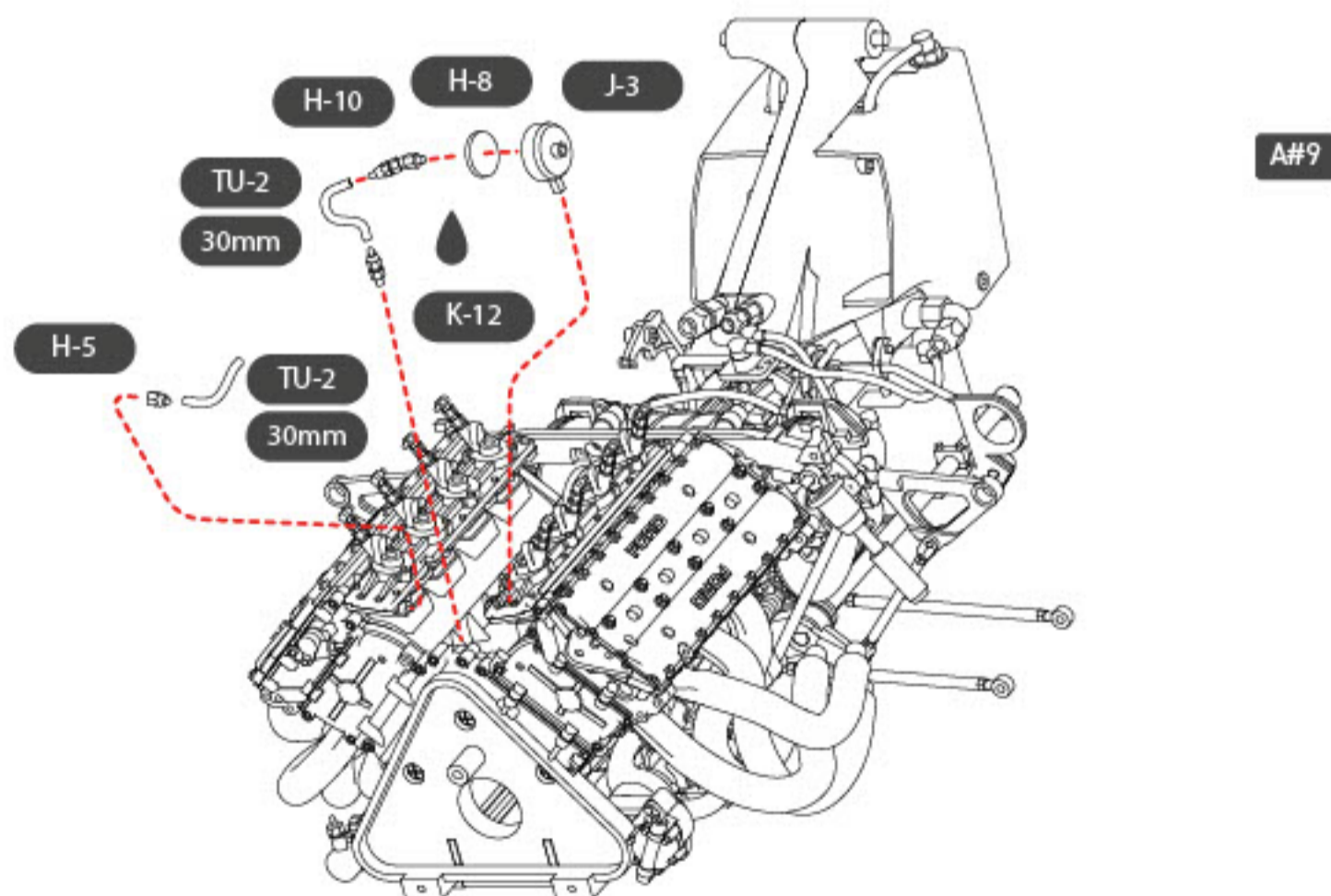
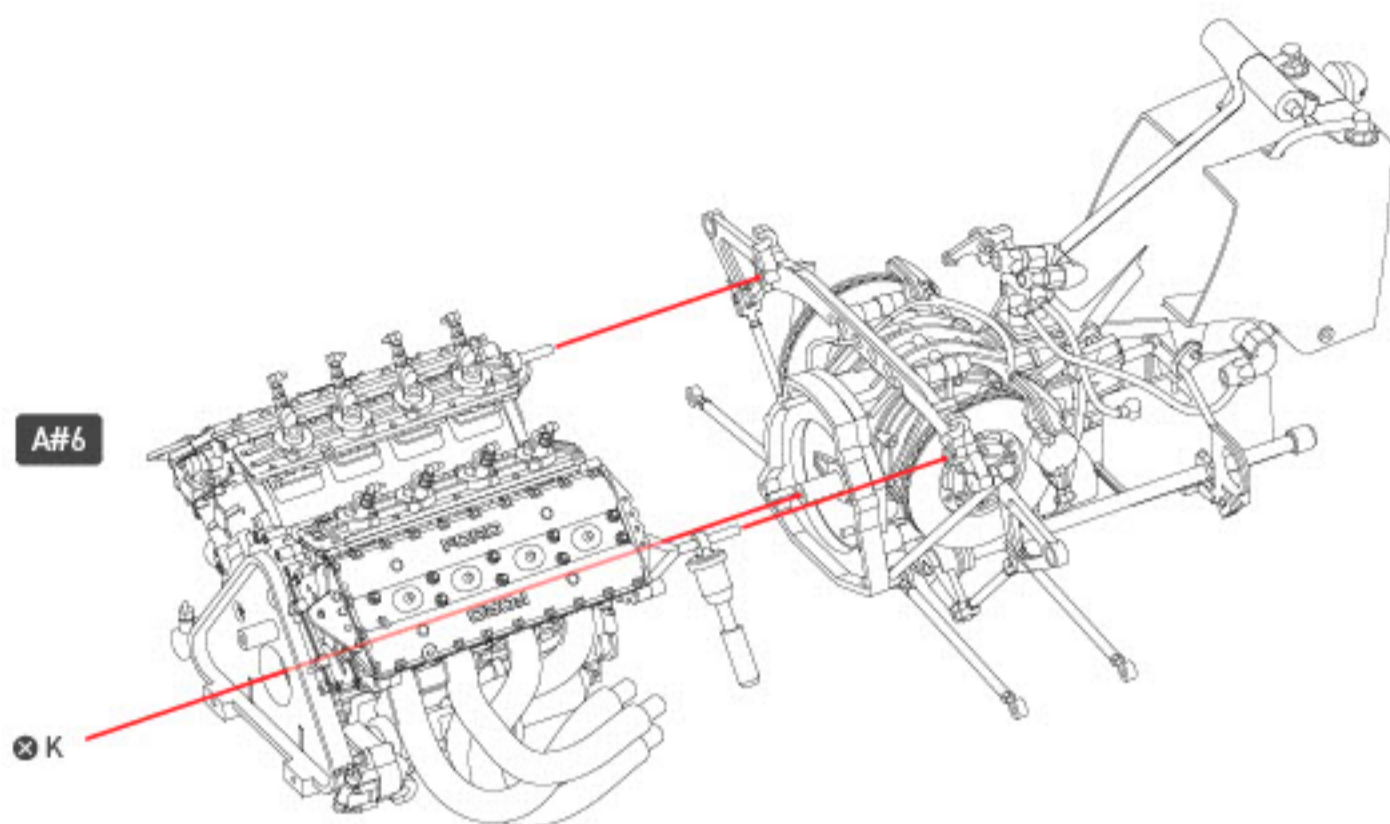

SCREW K = 1



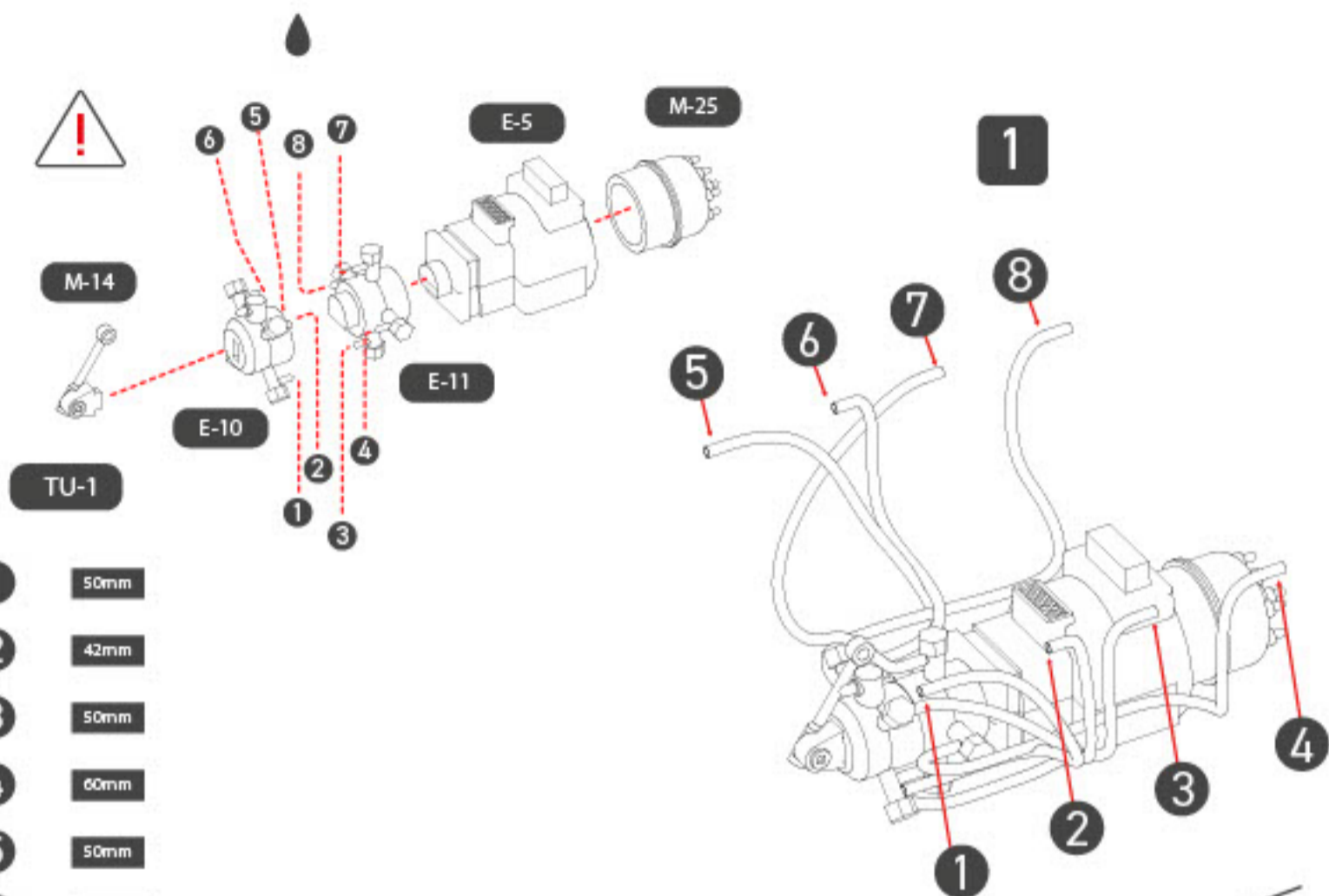

- 1 50mm
- 2 42mm
- 3 50mm
- 4 60mm
- 5 50mm
- 6 45mm
- 7 53mm
- 8 63mm

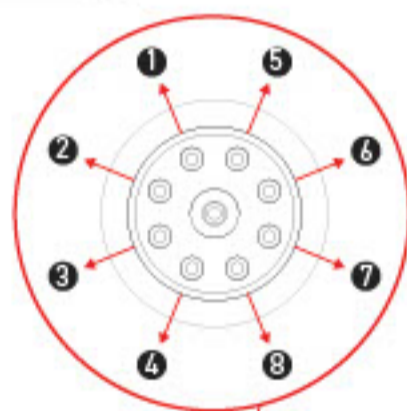

2

TU-1

- 1 83mm
- 2 73mm
- 3 63mm
- 4 55mm
- 5 75mm
- 6 66mm
- 7 60mm
- 8 56mm

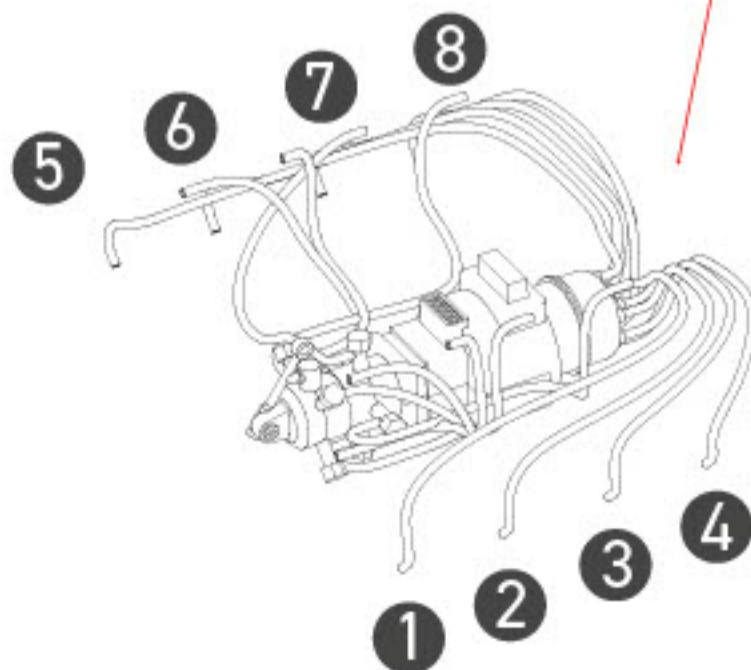

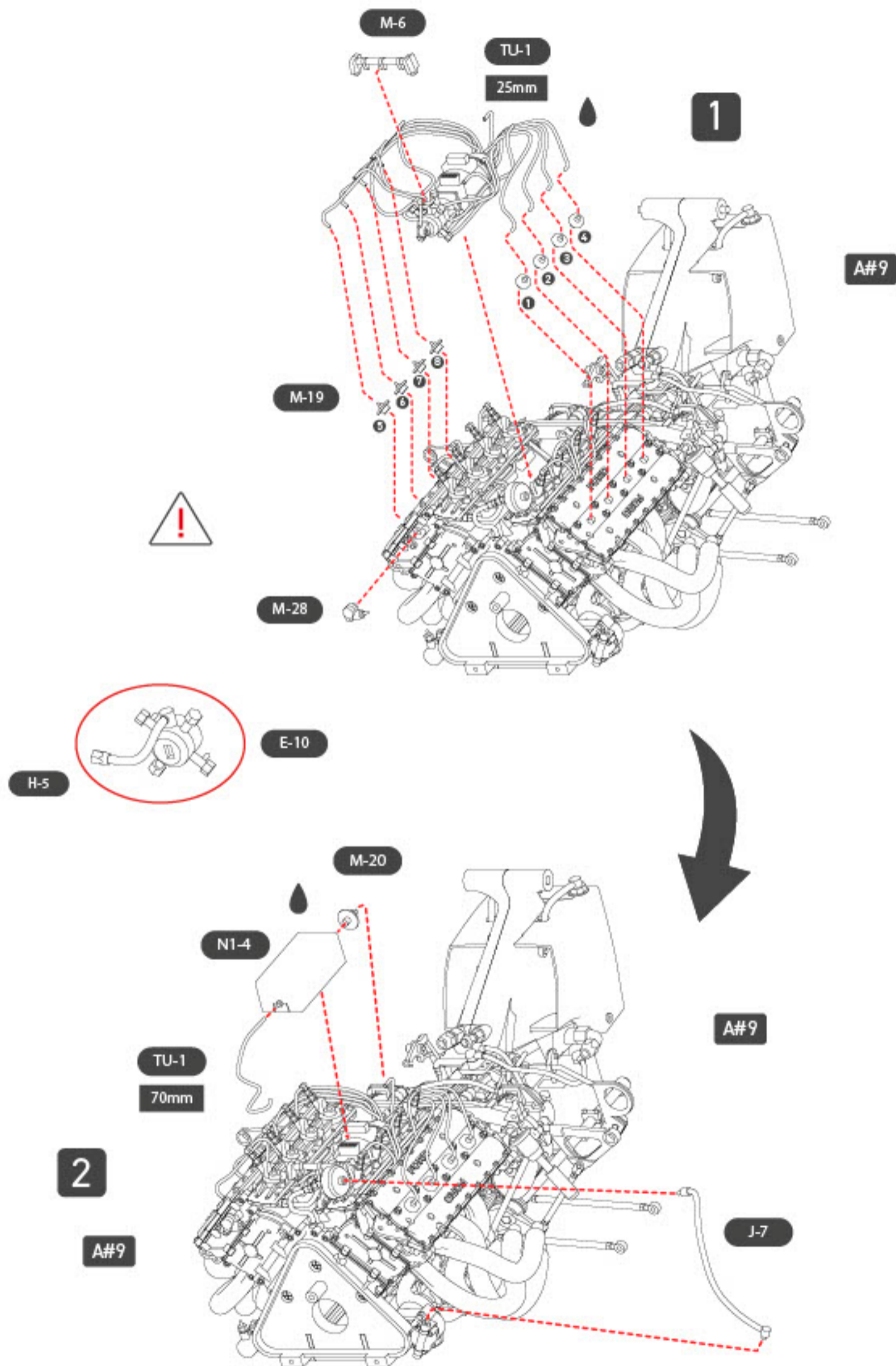

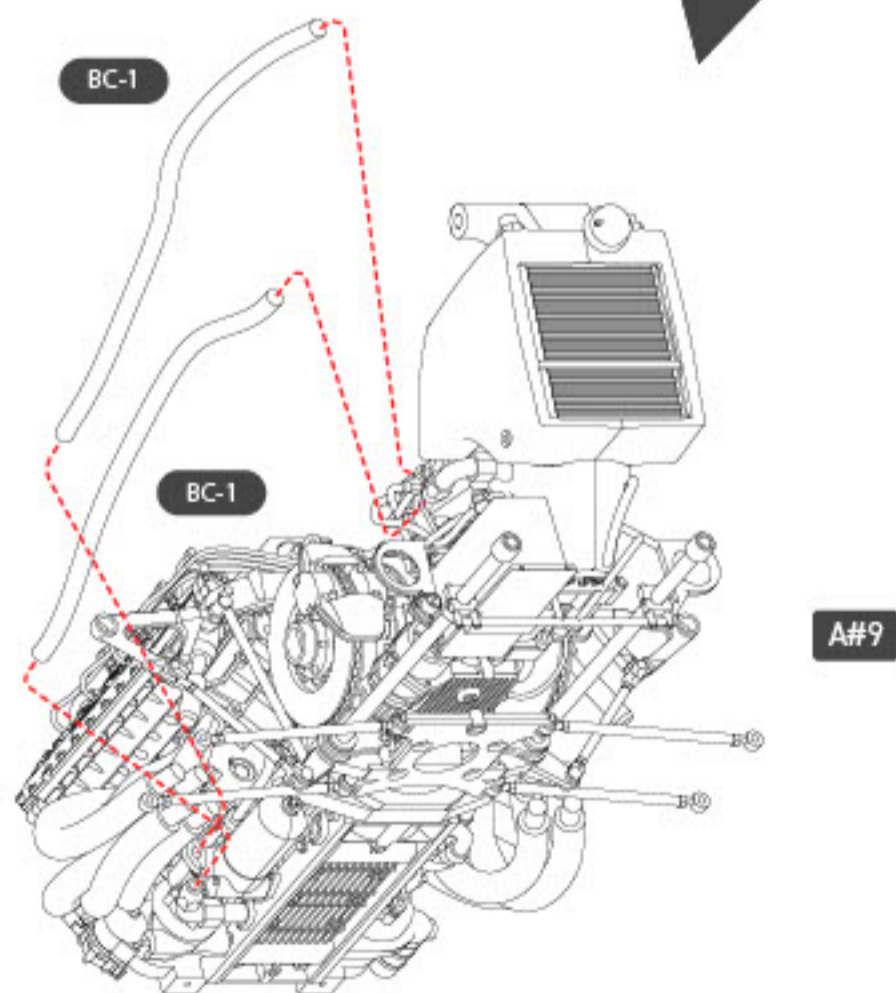
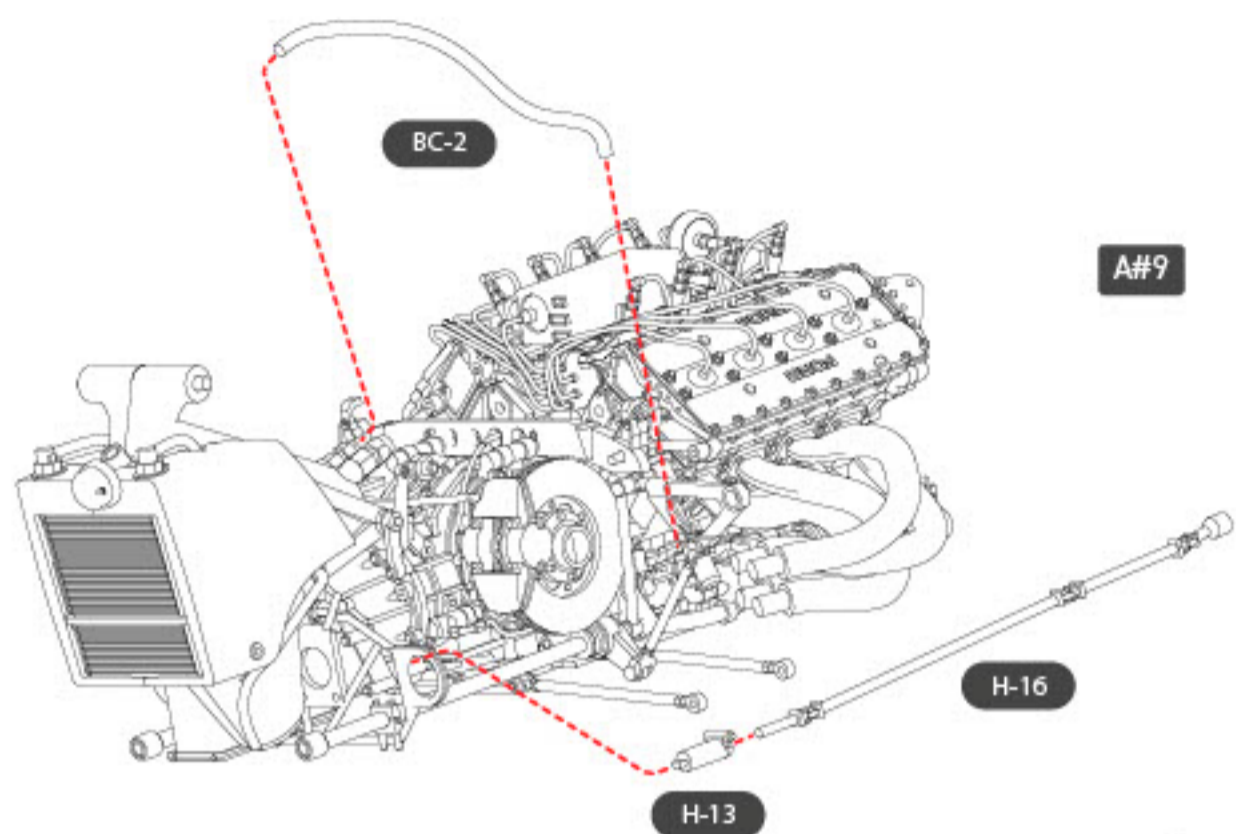



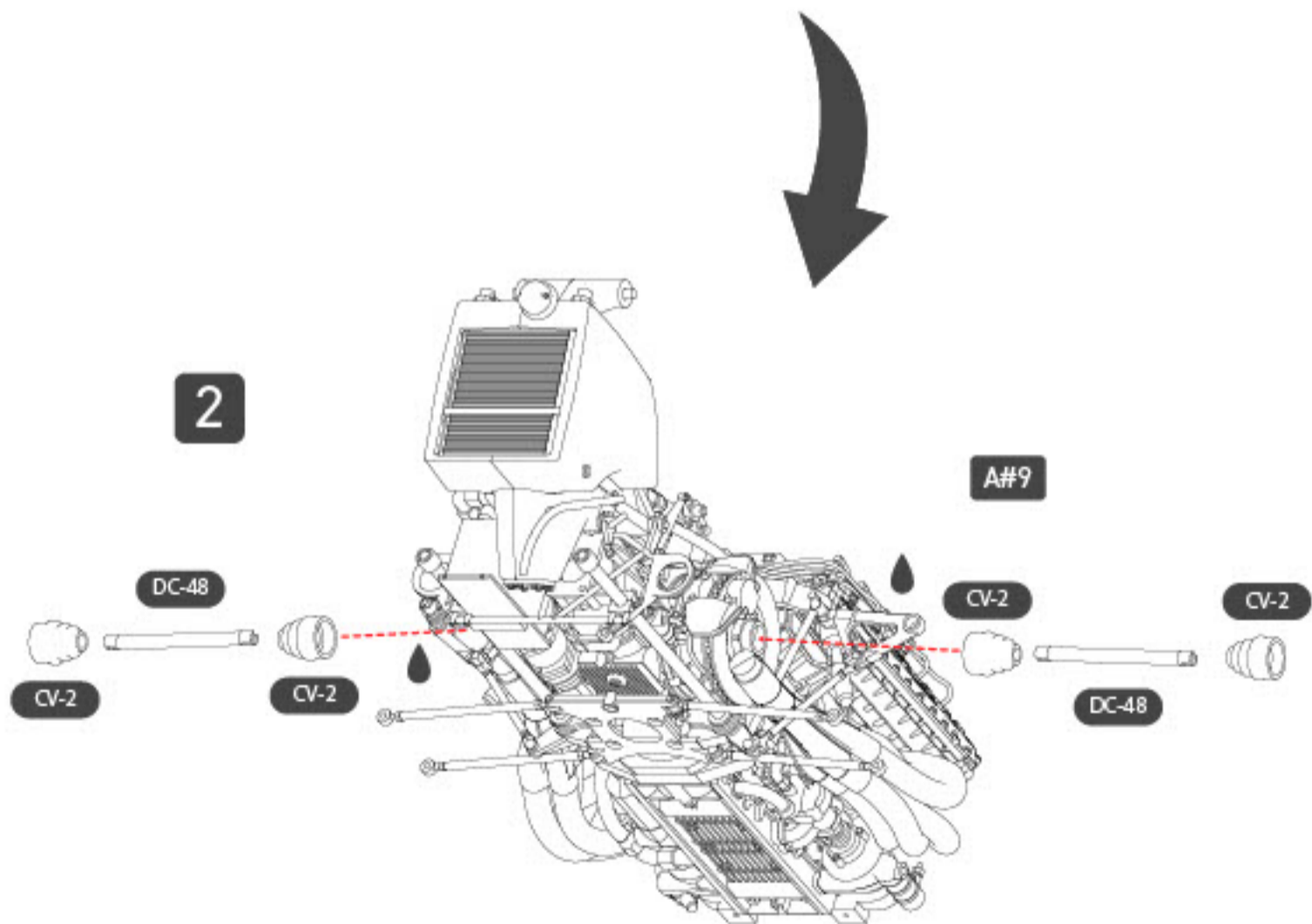
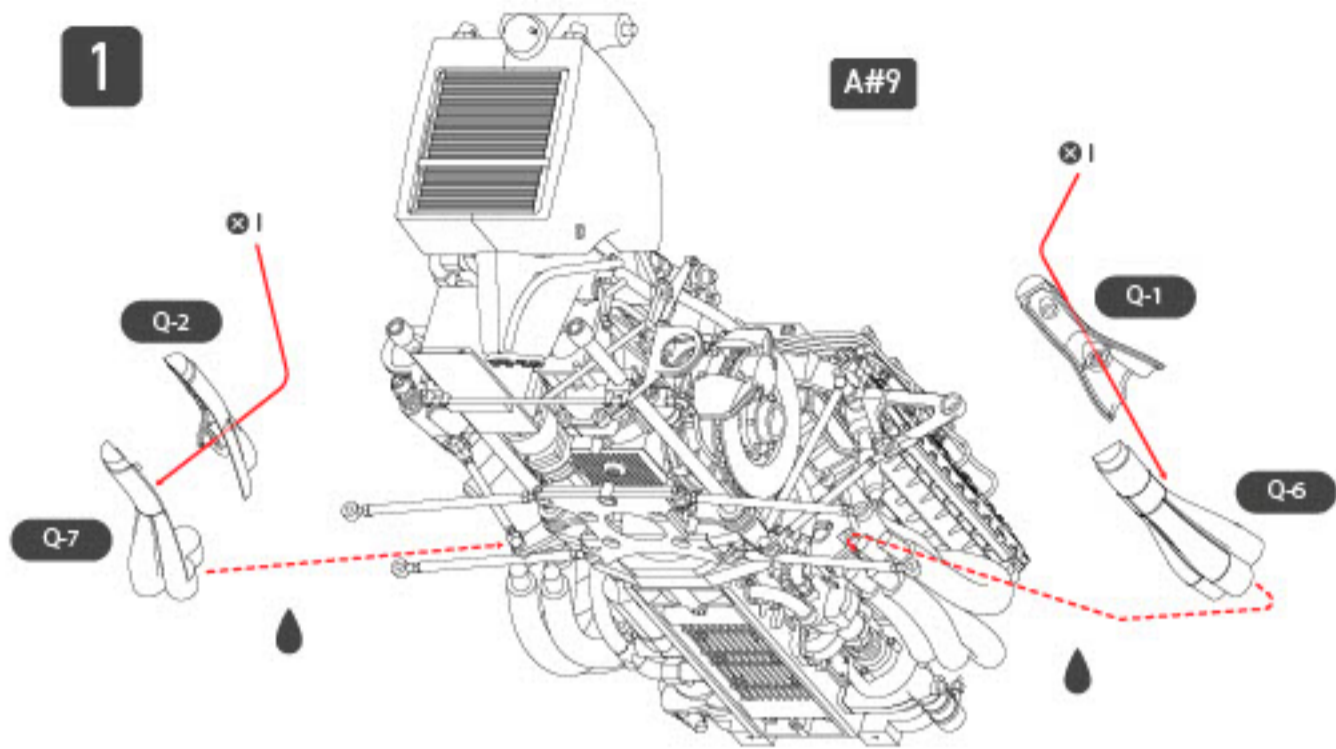

SCREW 1 = 2

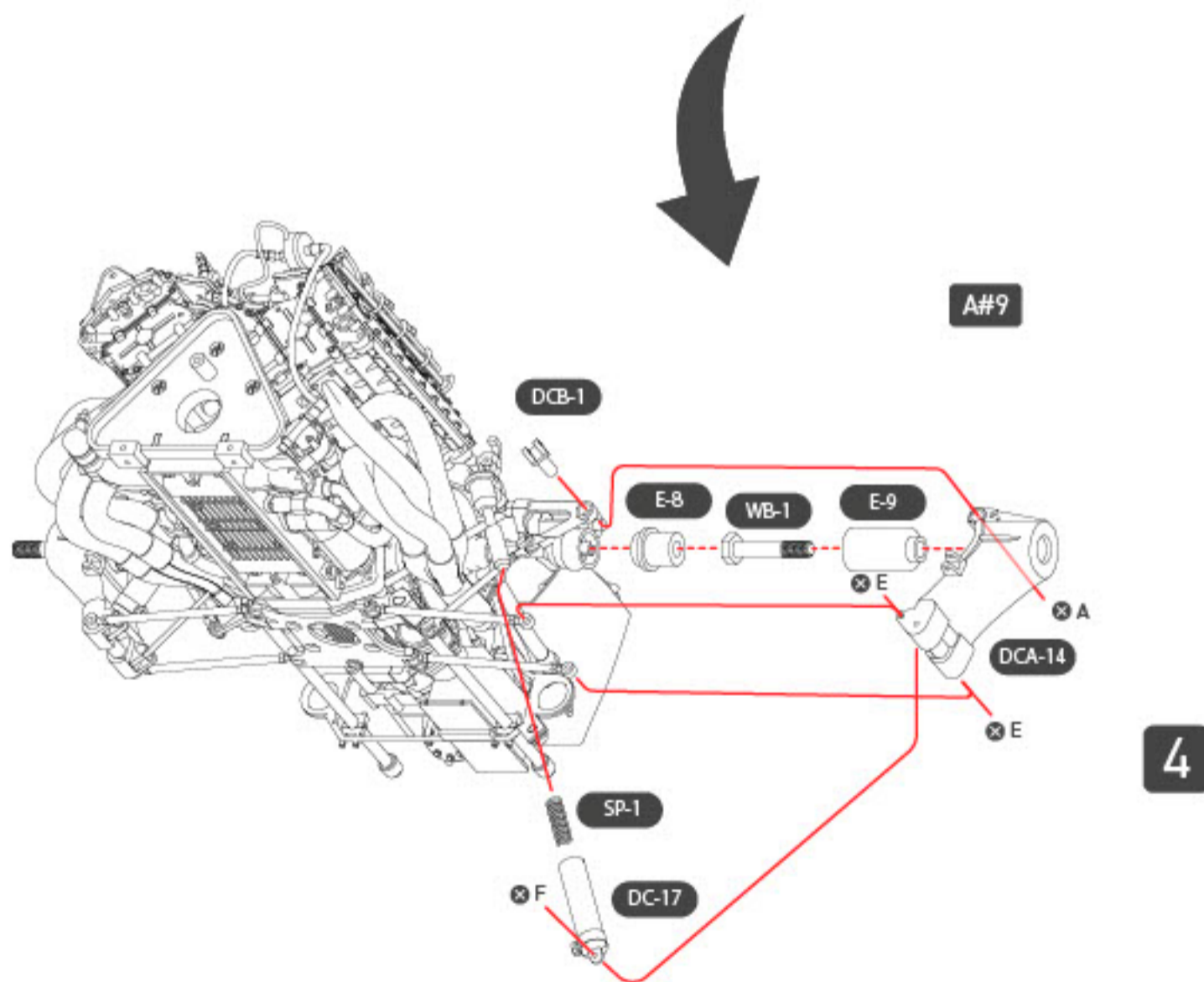
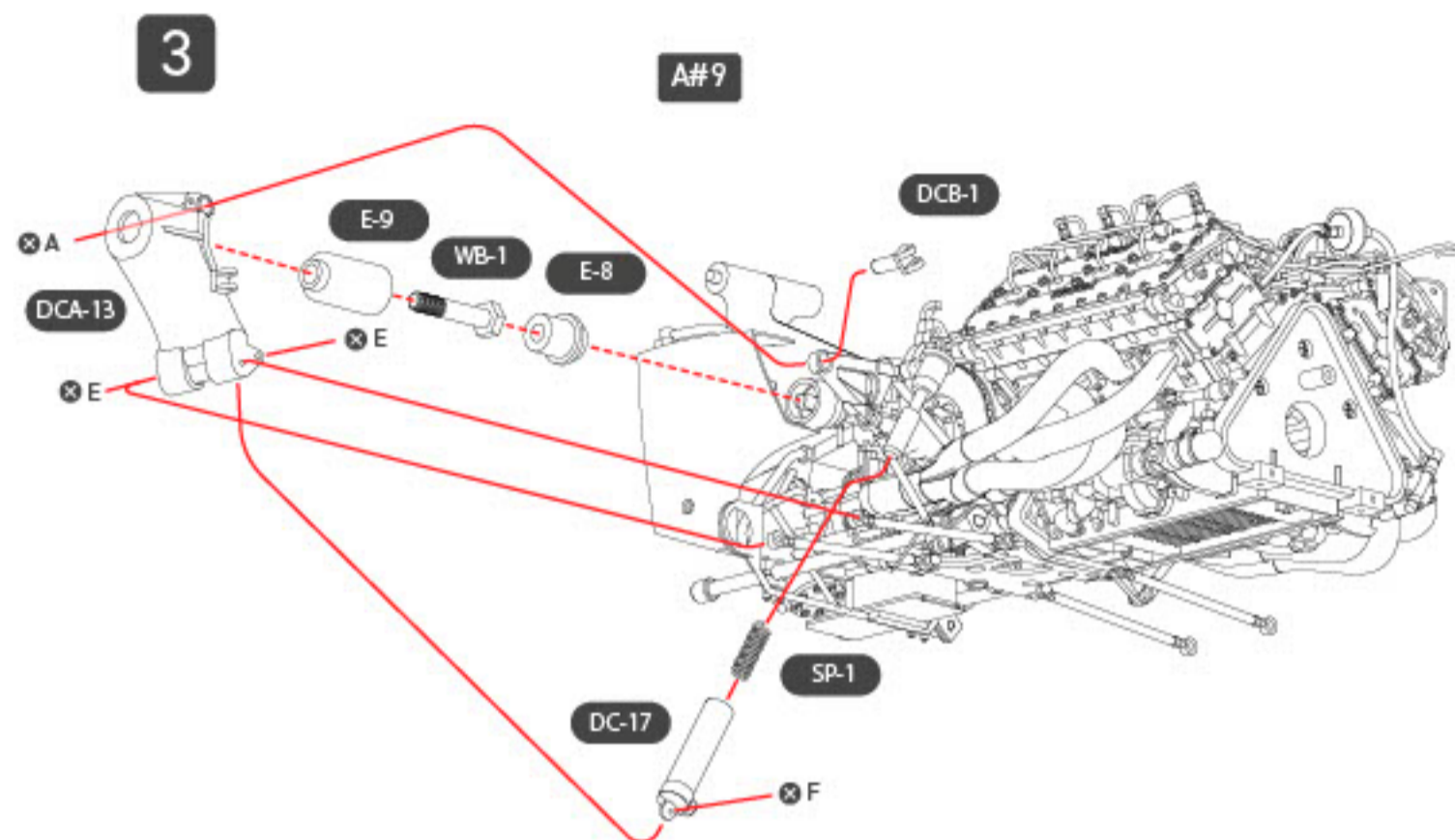

SCREW A = 2  
 SCREW E = 4  
 SCREW F = 2





3

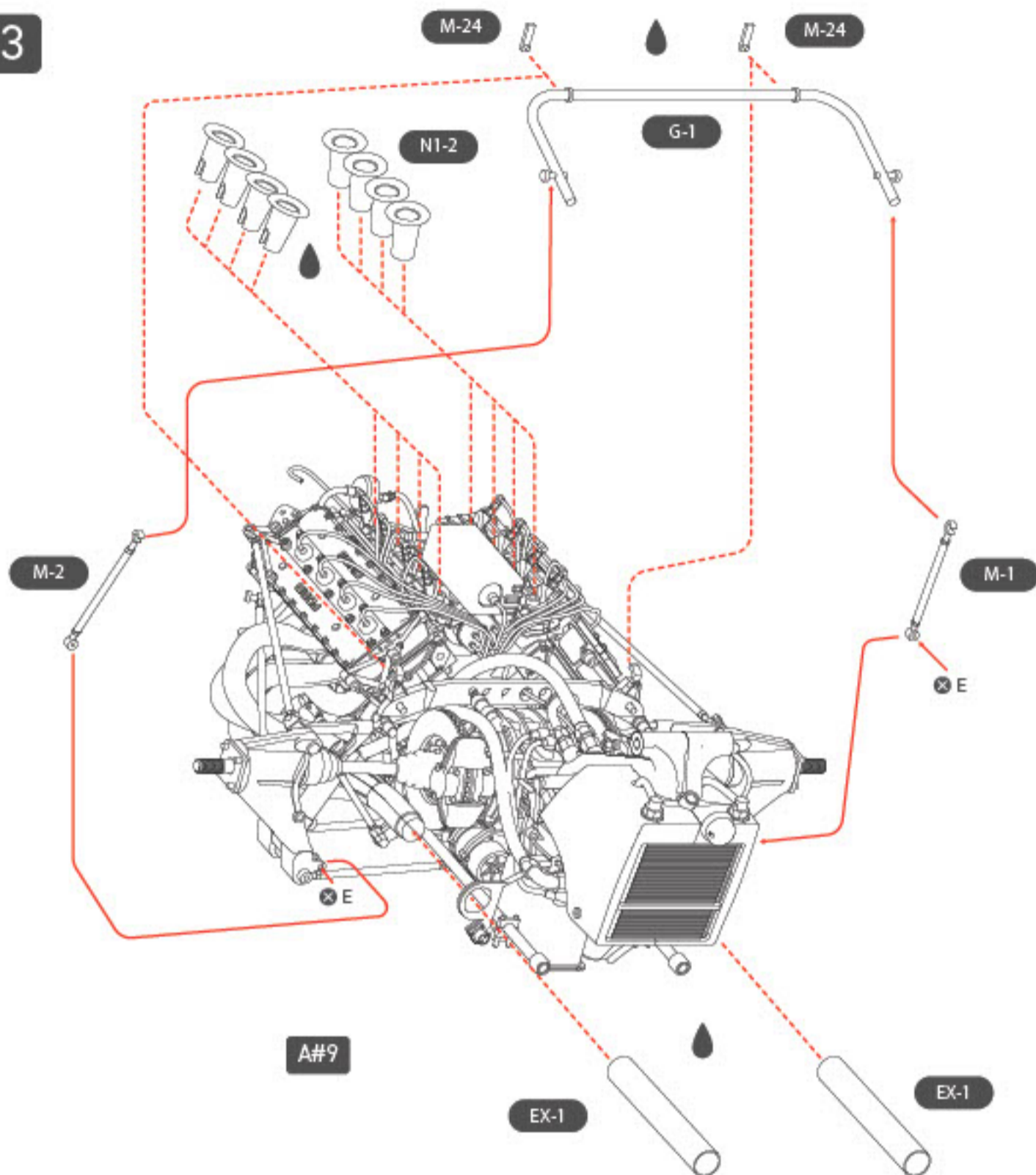

SCREW E = 2

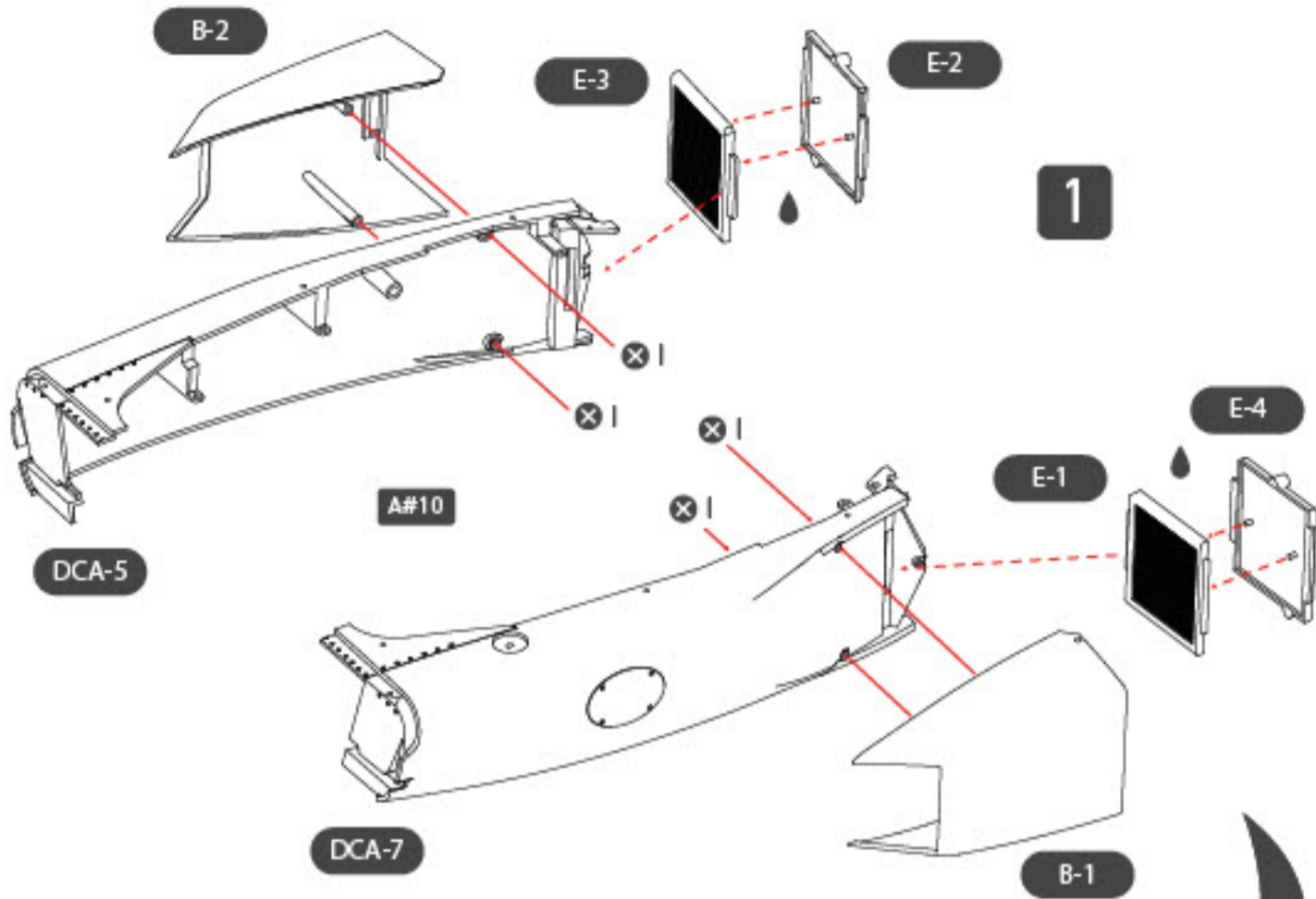

**1**

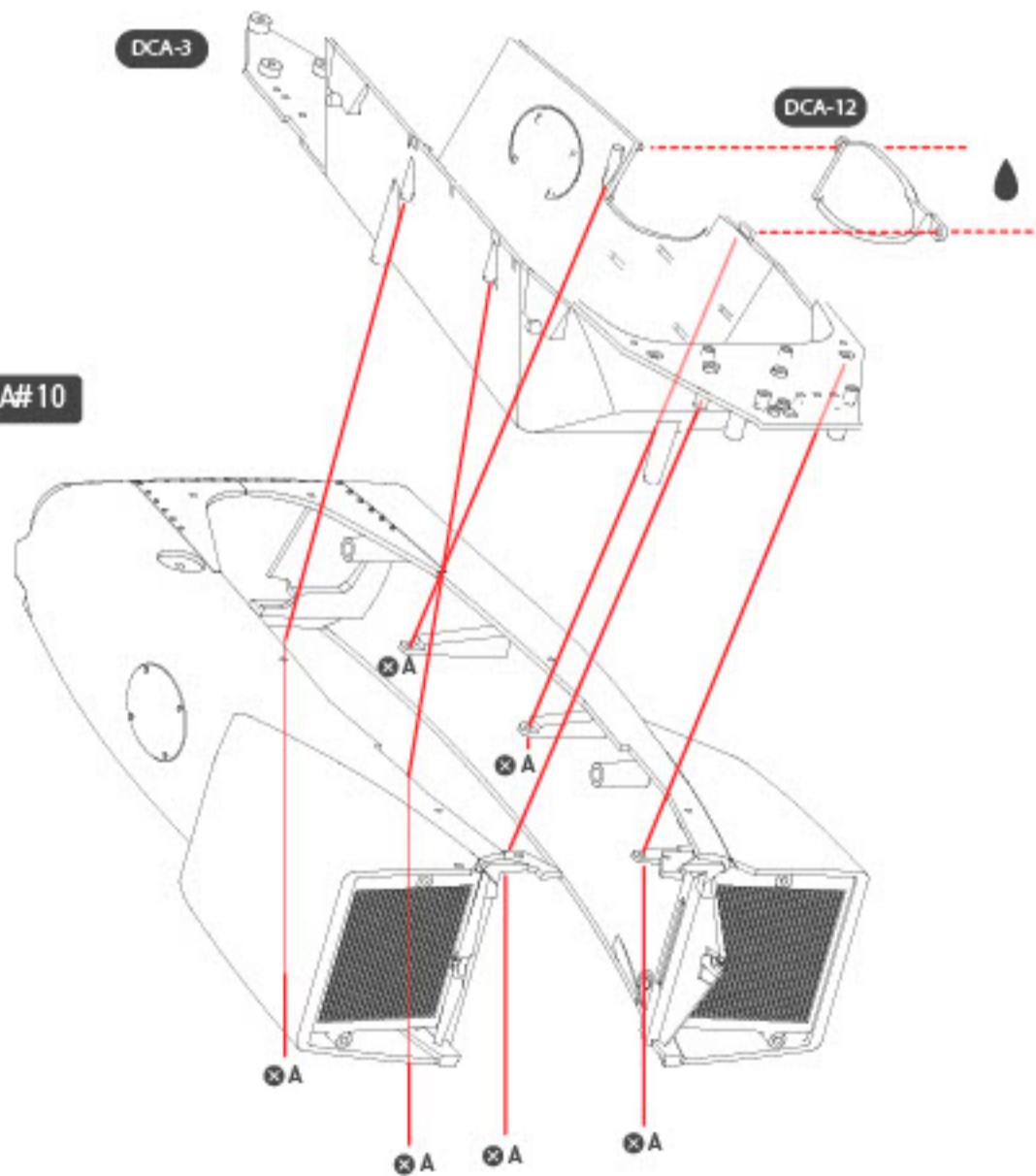

**2**

SCREW A = 6  
SCREW I = 4

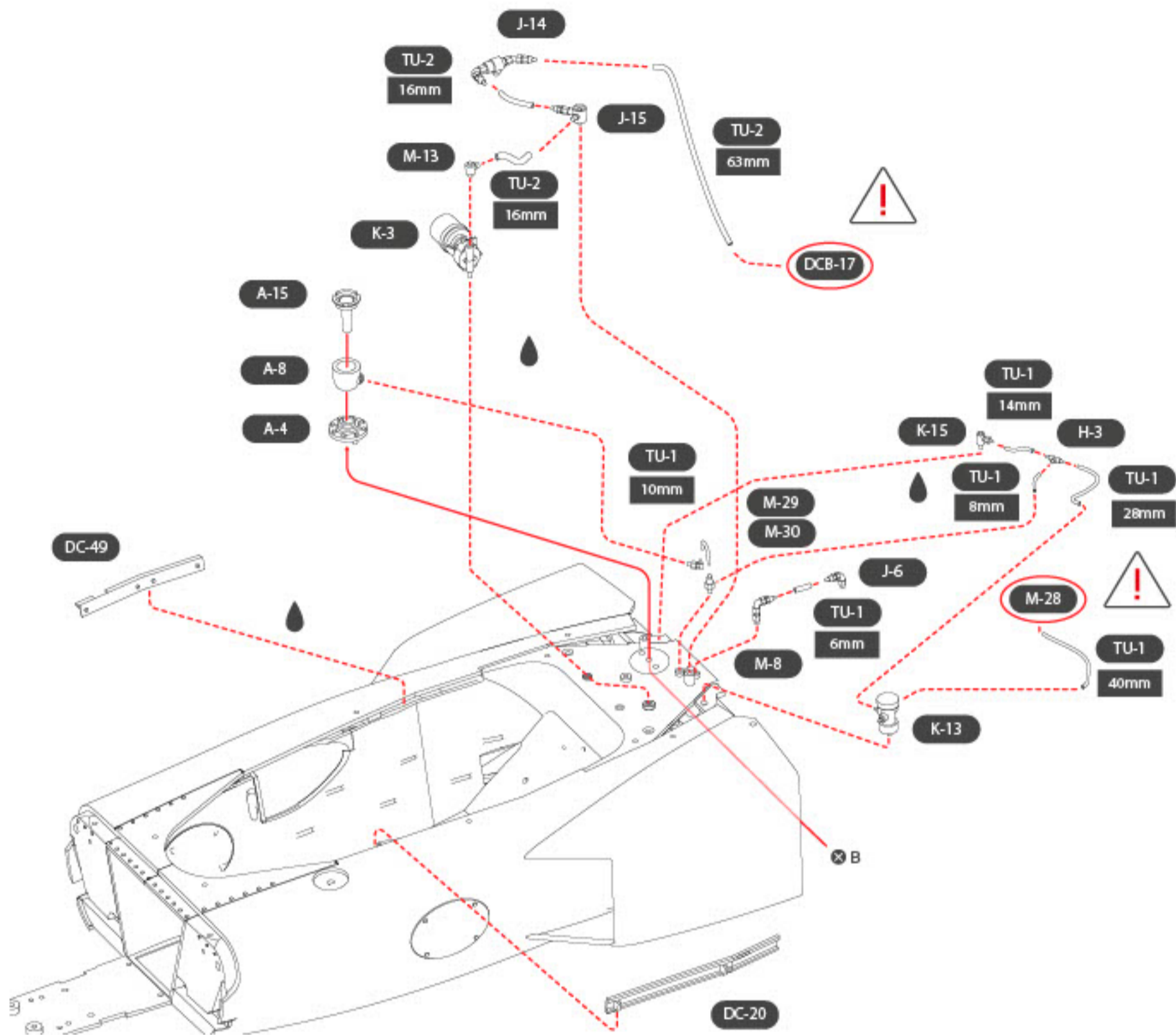

A#10

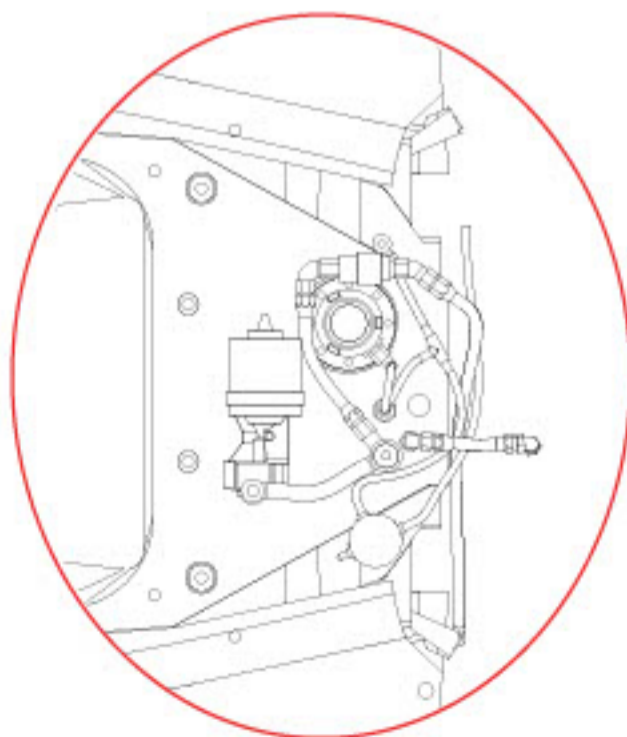

SCREW B = 1



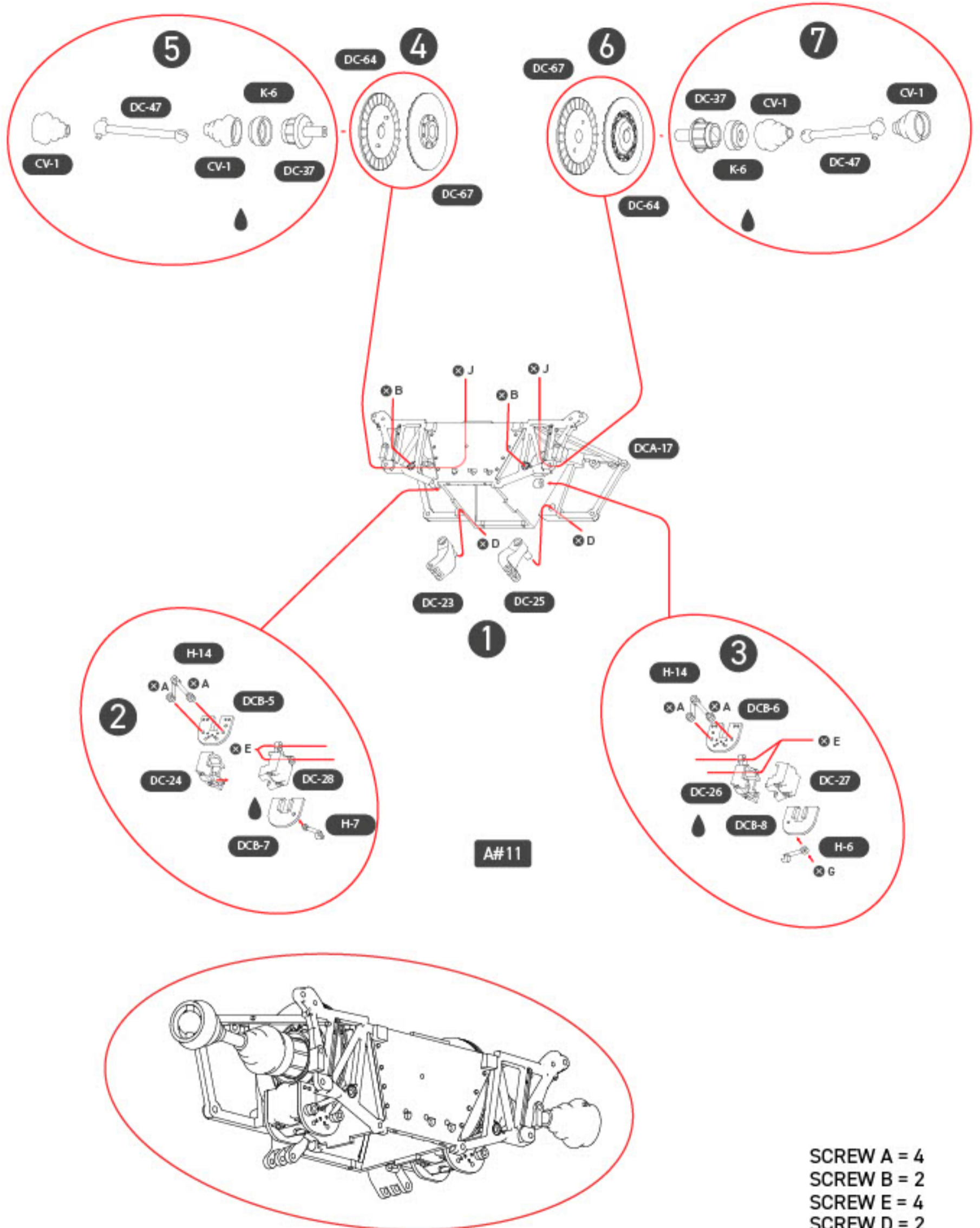

- SCREW A = 4
- SCREW B = 2
- SCREW E = 4
- SCREW D = 2
- SCREW G = 1
- SCREW J = 2

1

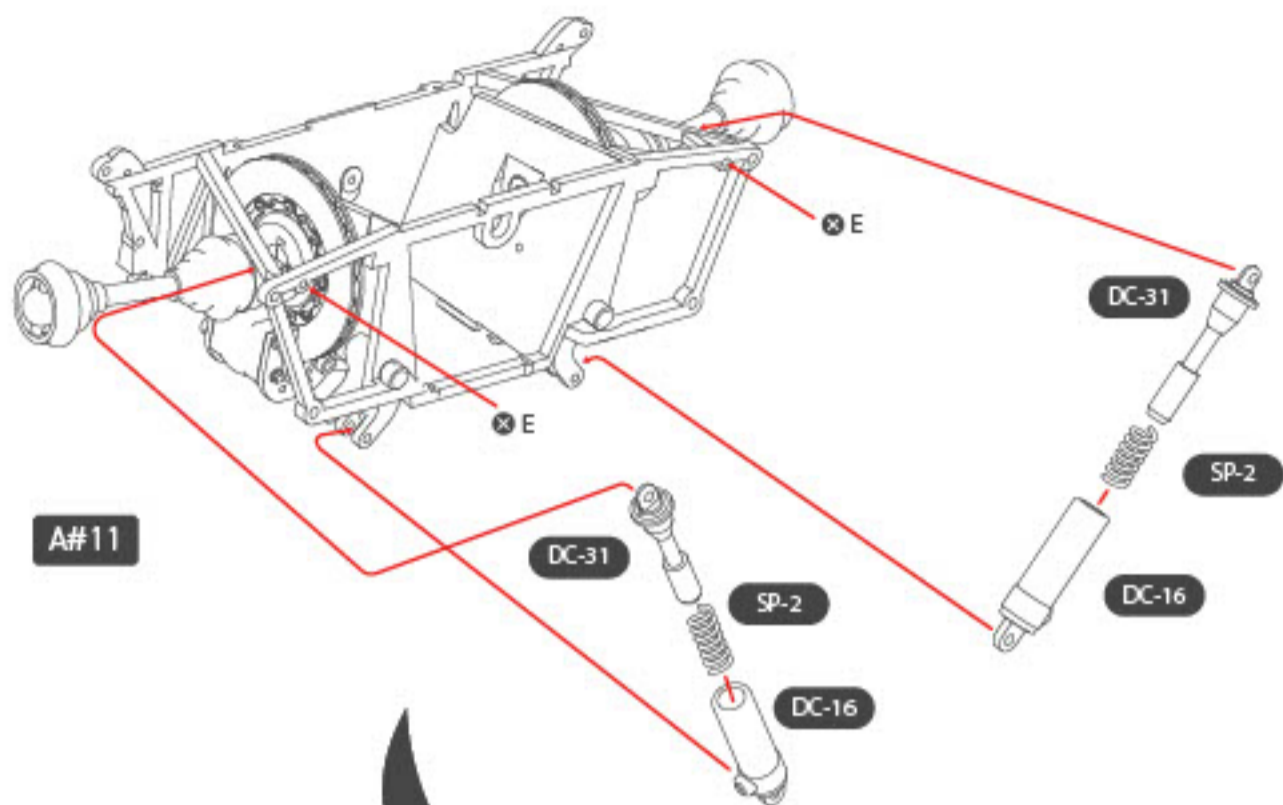

A#11

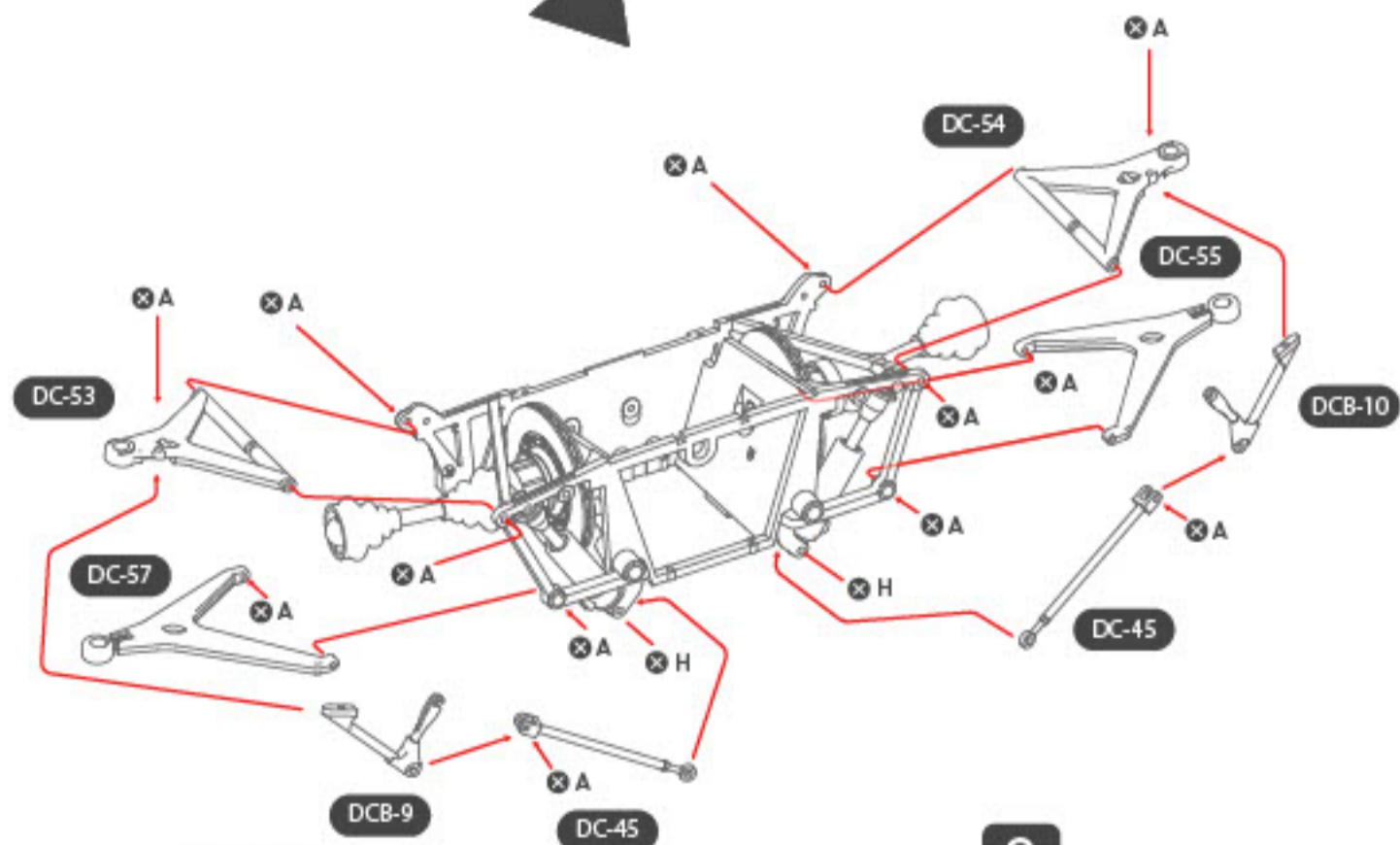

2

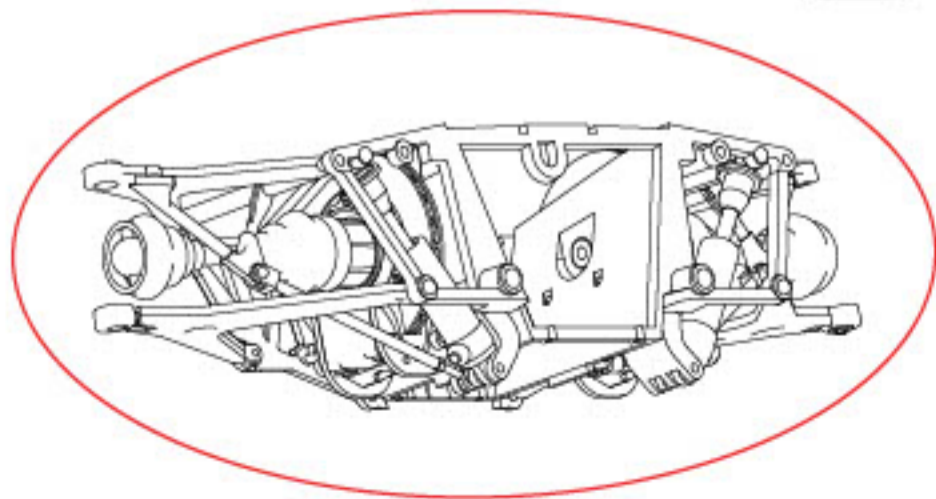

SCREW A = 14  
 SCREW E = 2  
 SCREW H = 2

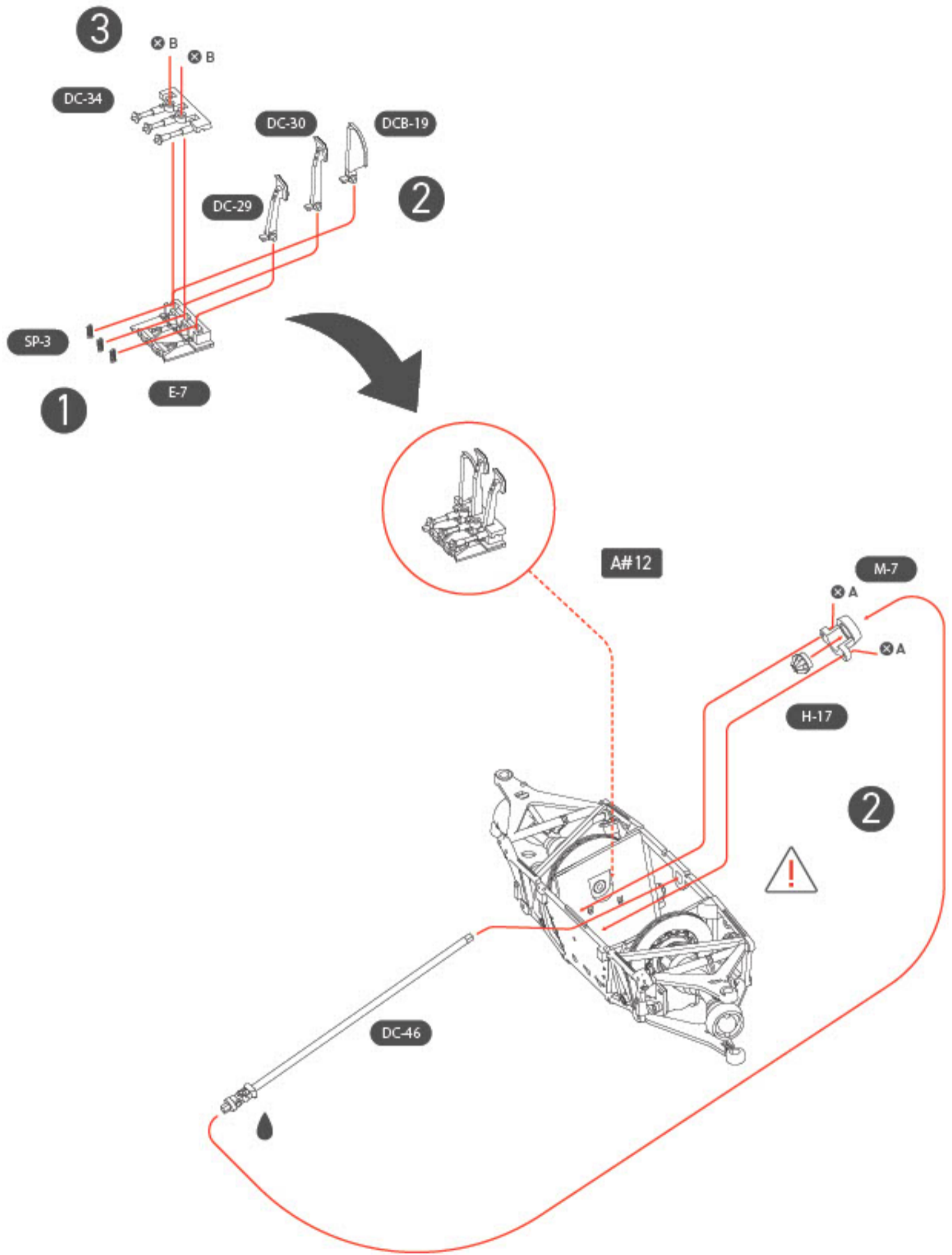

SCREW A = 2  
SCREW B = 2



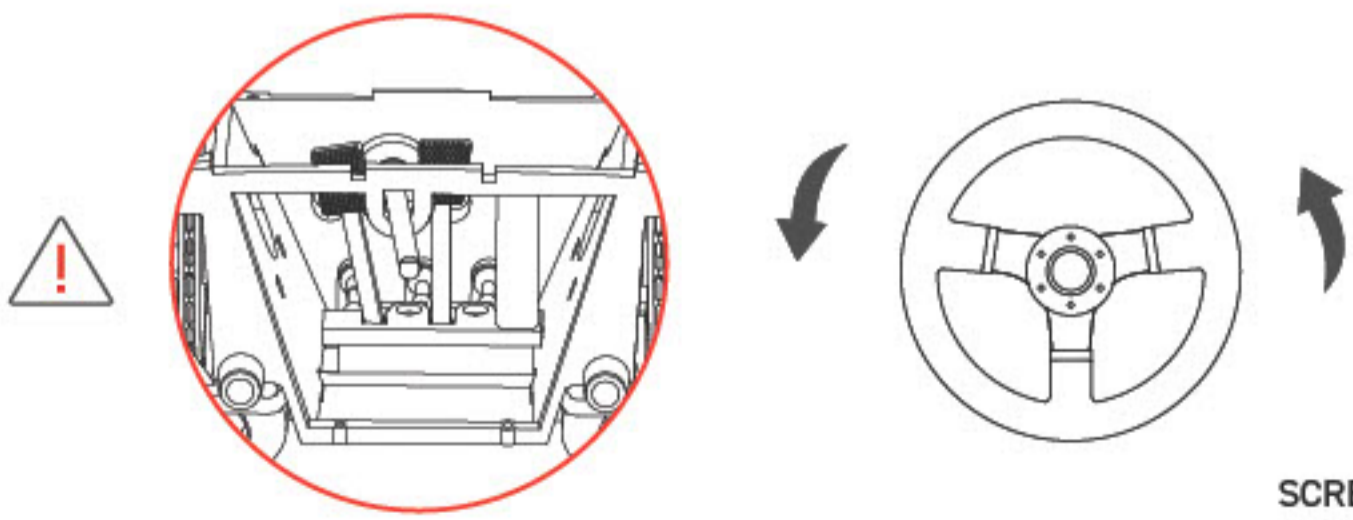
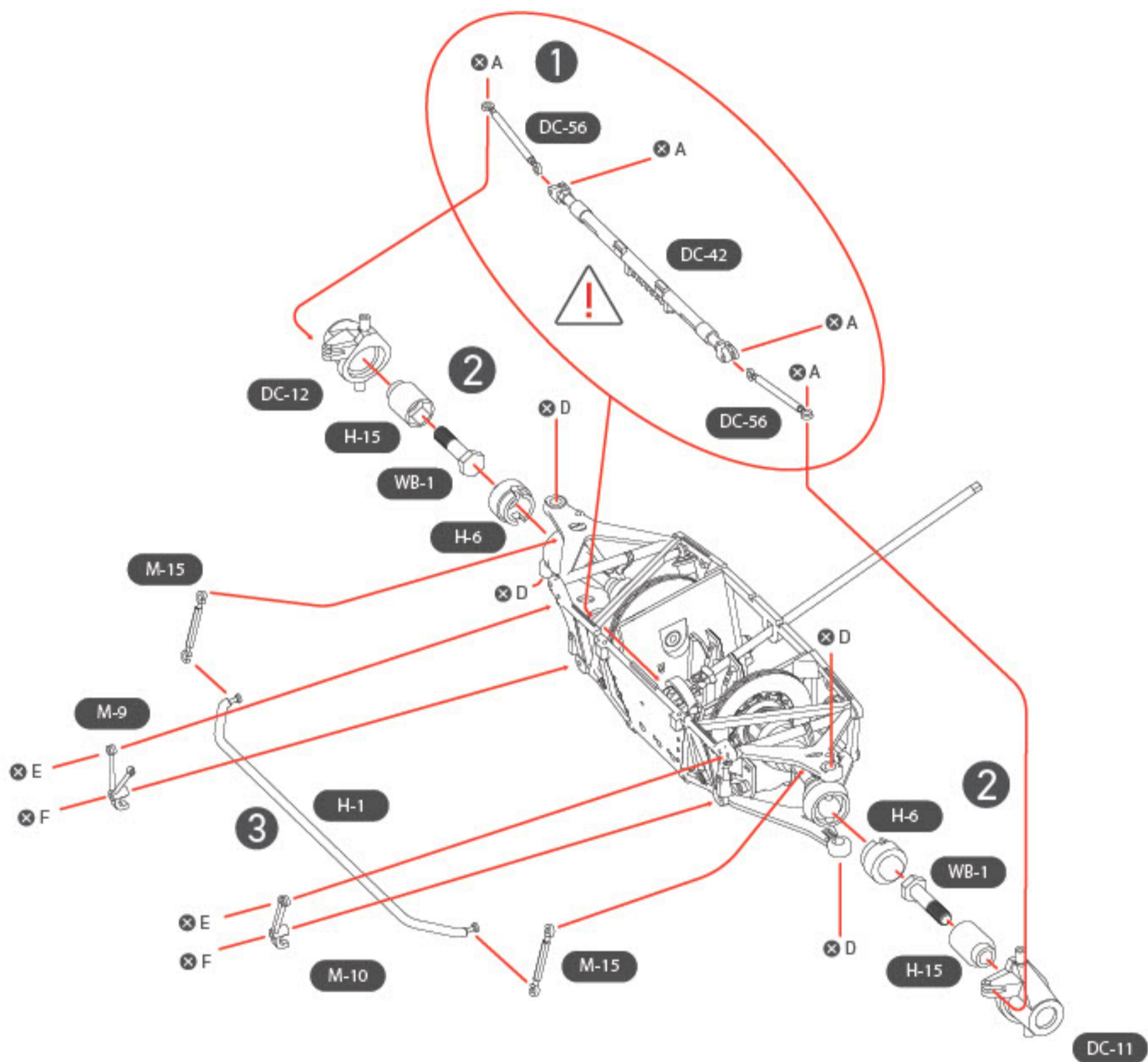

- SCREW A = 4
- SCREW D = 4
- SCREW E = 2
- SCREW F = 2

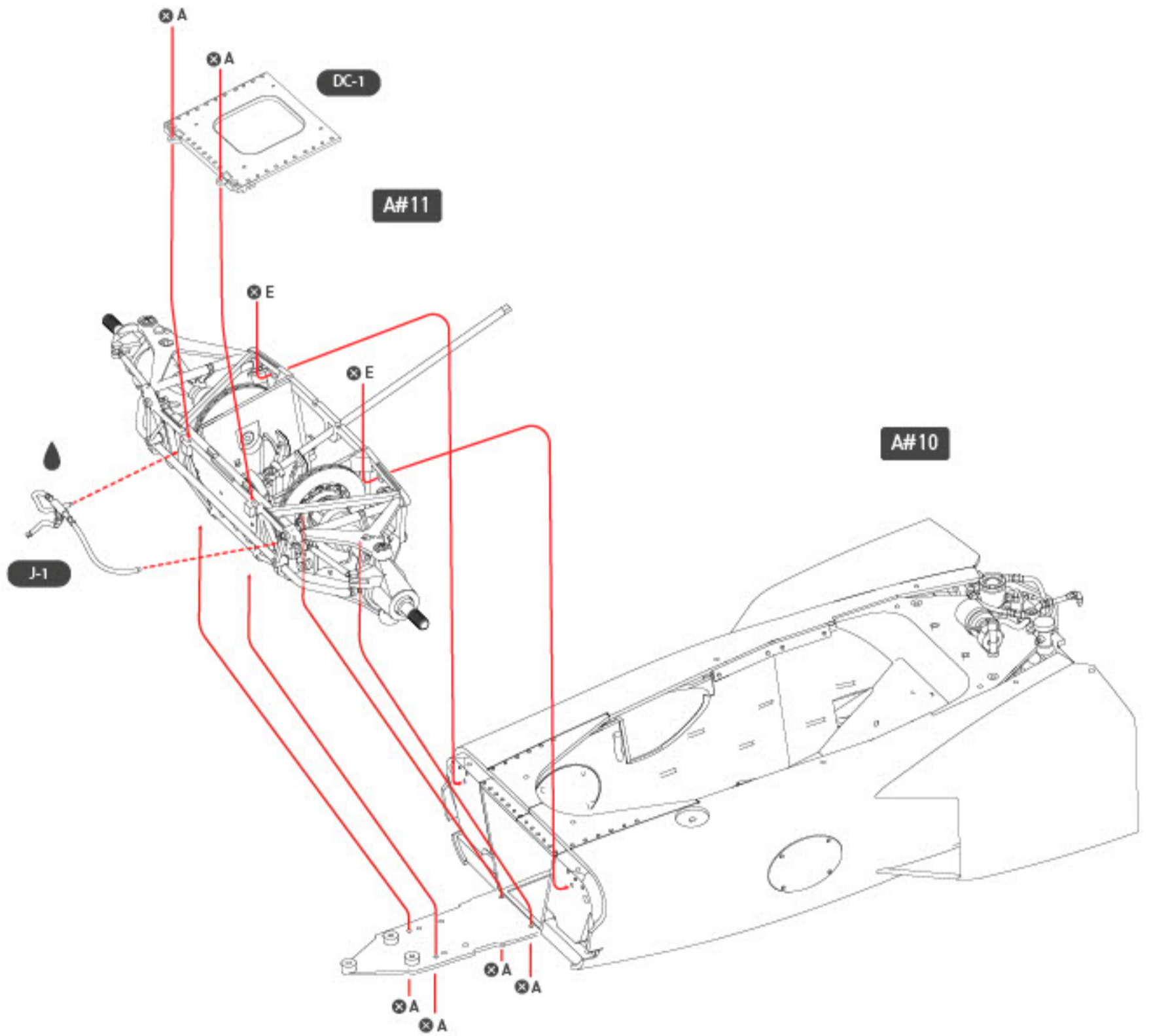

SCREW A = 6  
SCREW E = 2

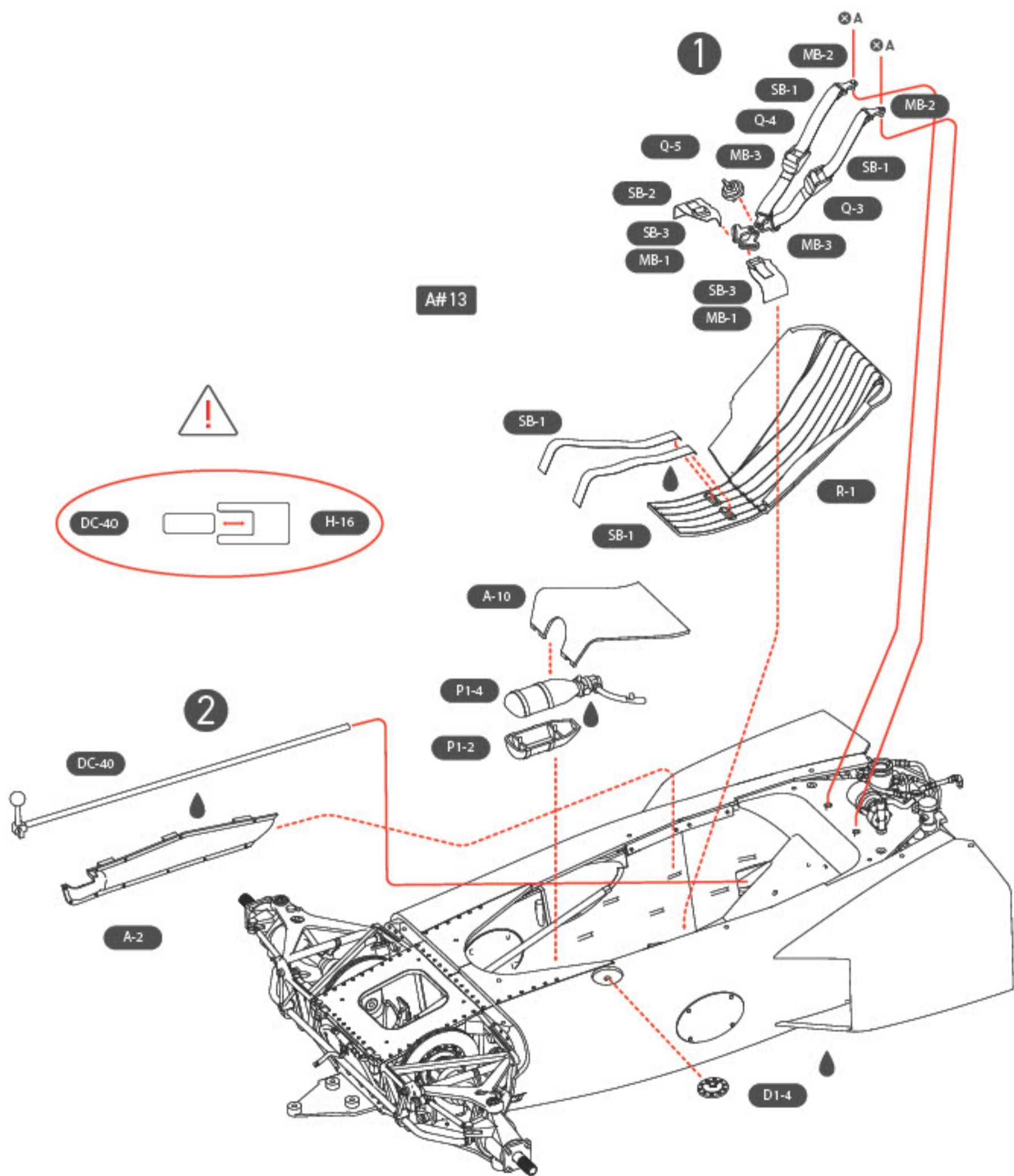

SCREW A = 2



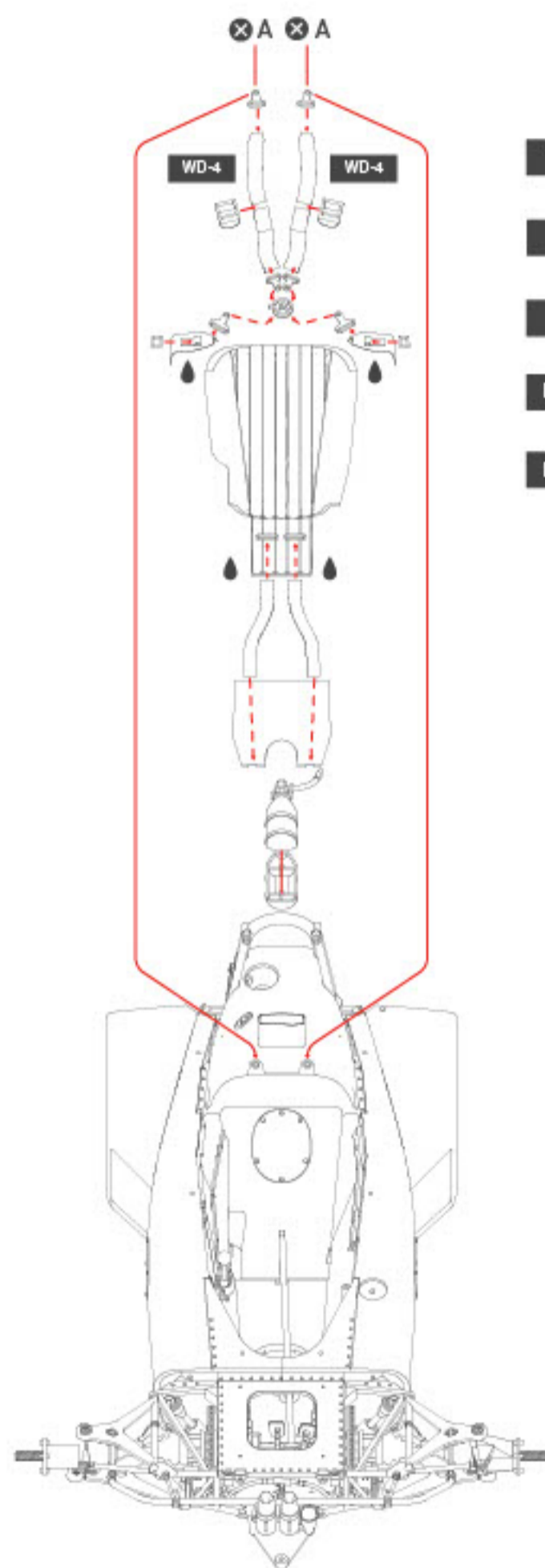

Top	SB-1	40mm
Mid	SB-1	45mm
Lap	SB-2	30mm
Lap 2	SB-3	11mm
Lower	SB-1	67mm

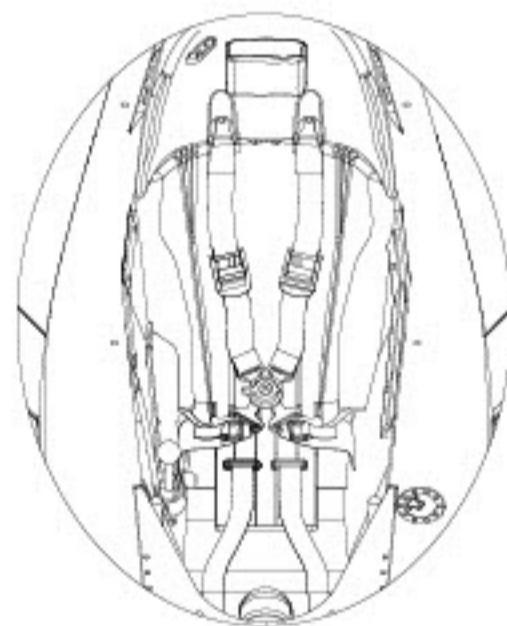

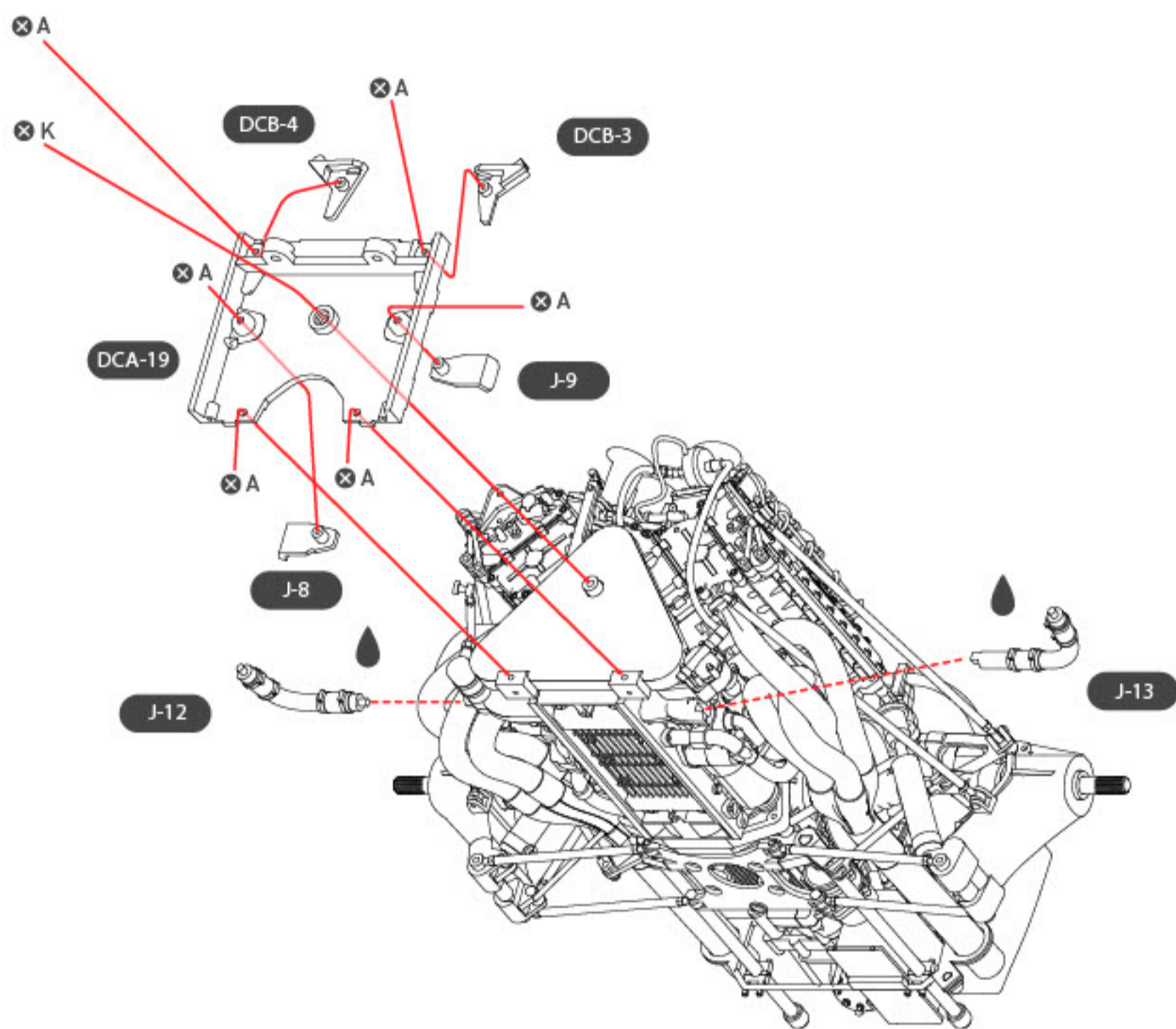

SCREW A = 6  
 SCREW K = 1

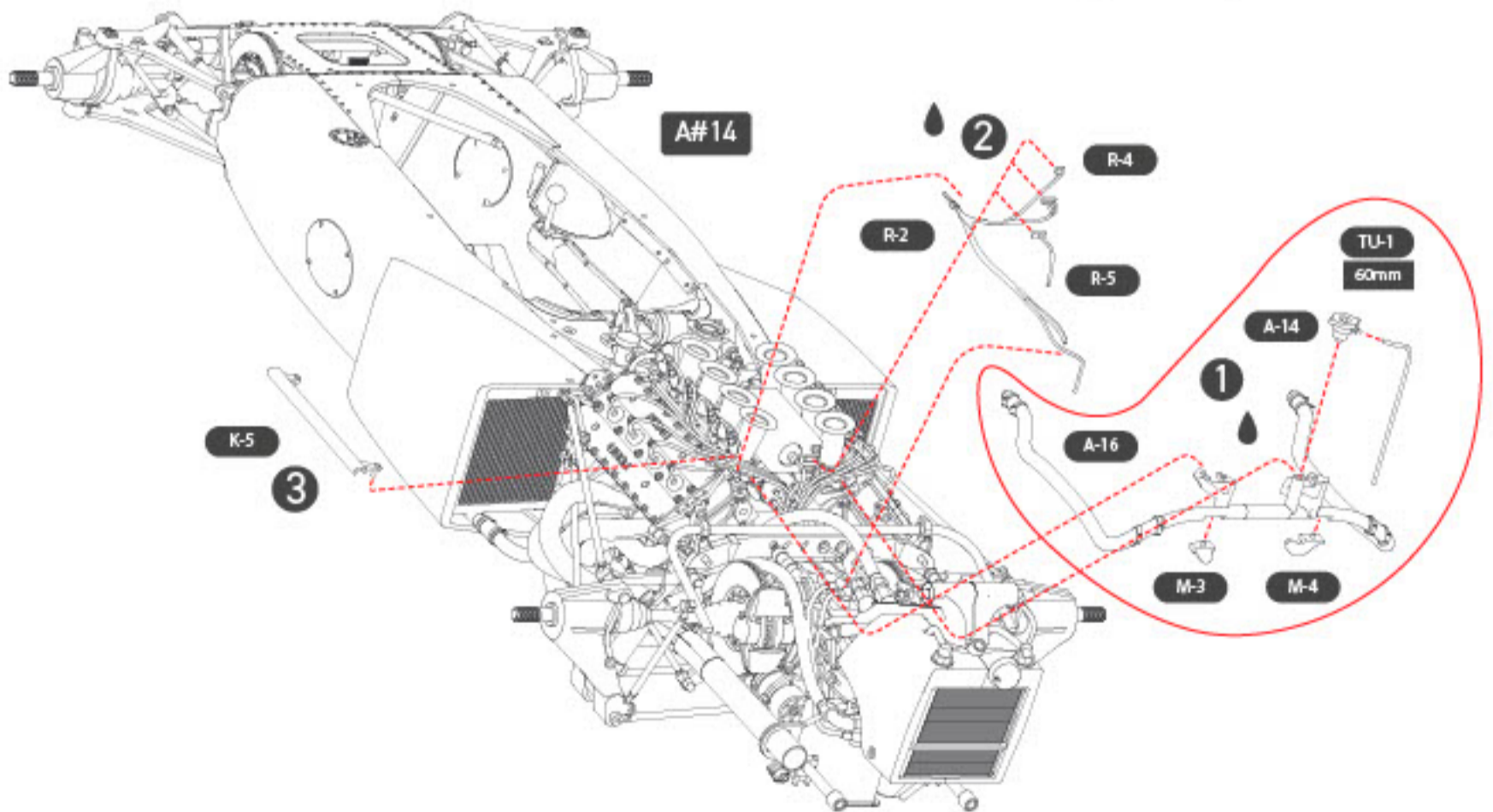
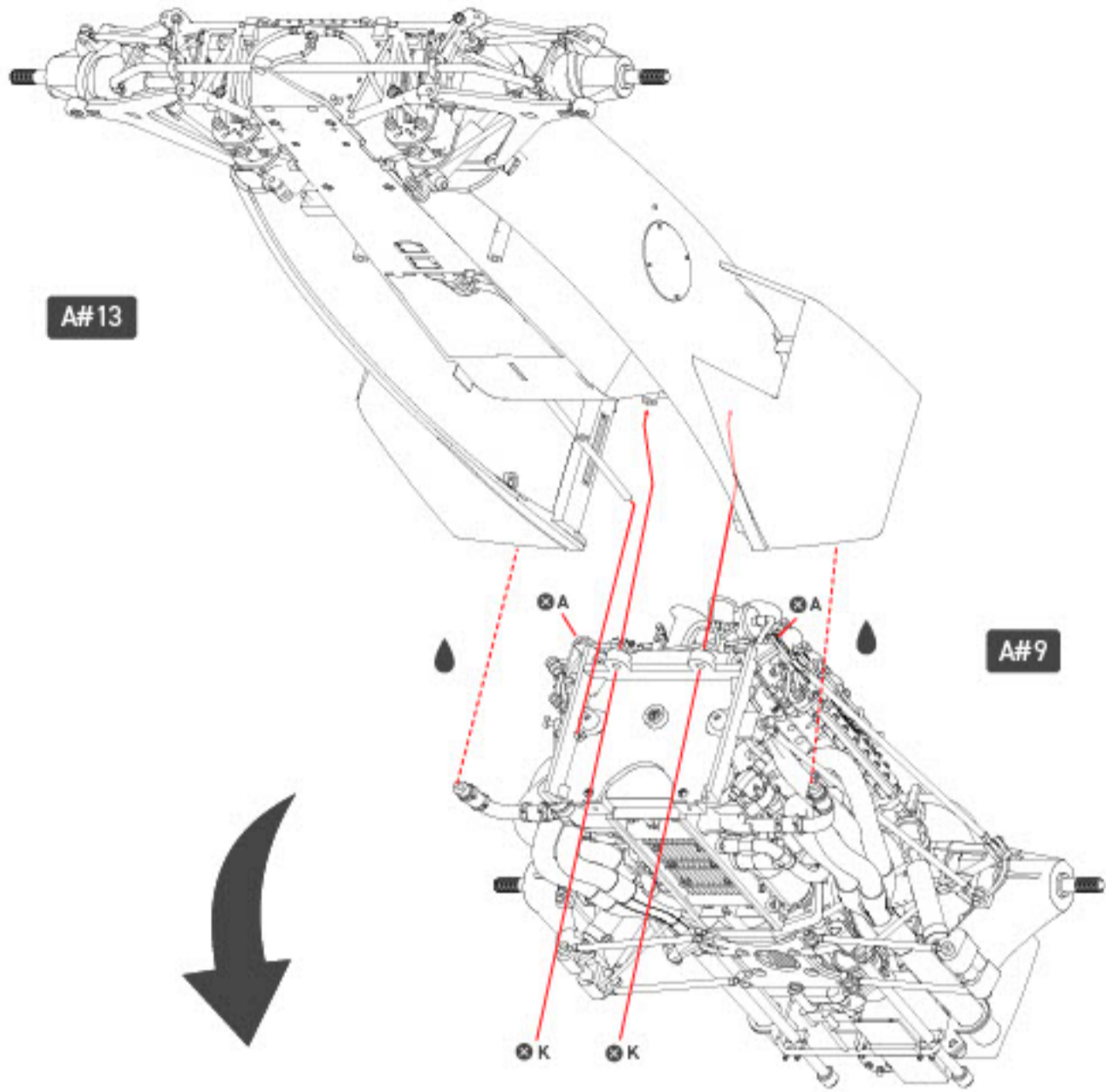

SCREW A = 2  
SCREW K = 2



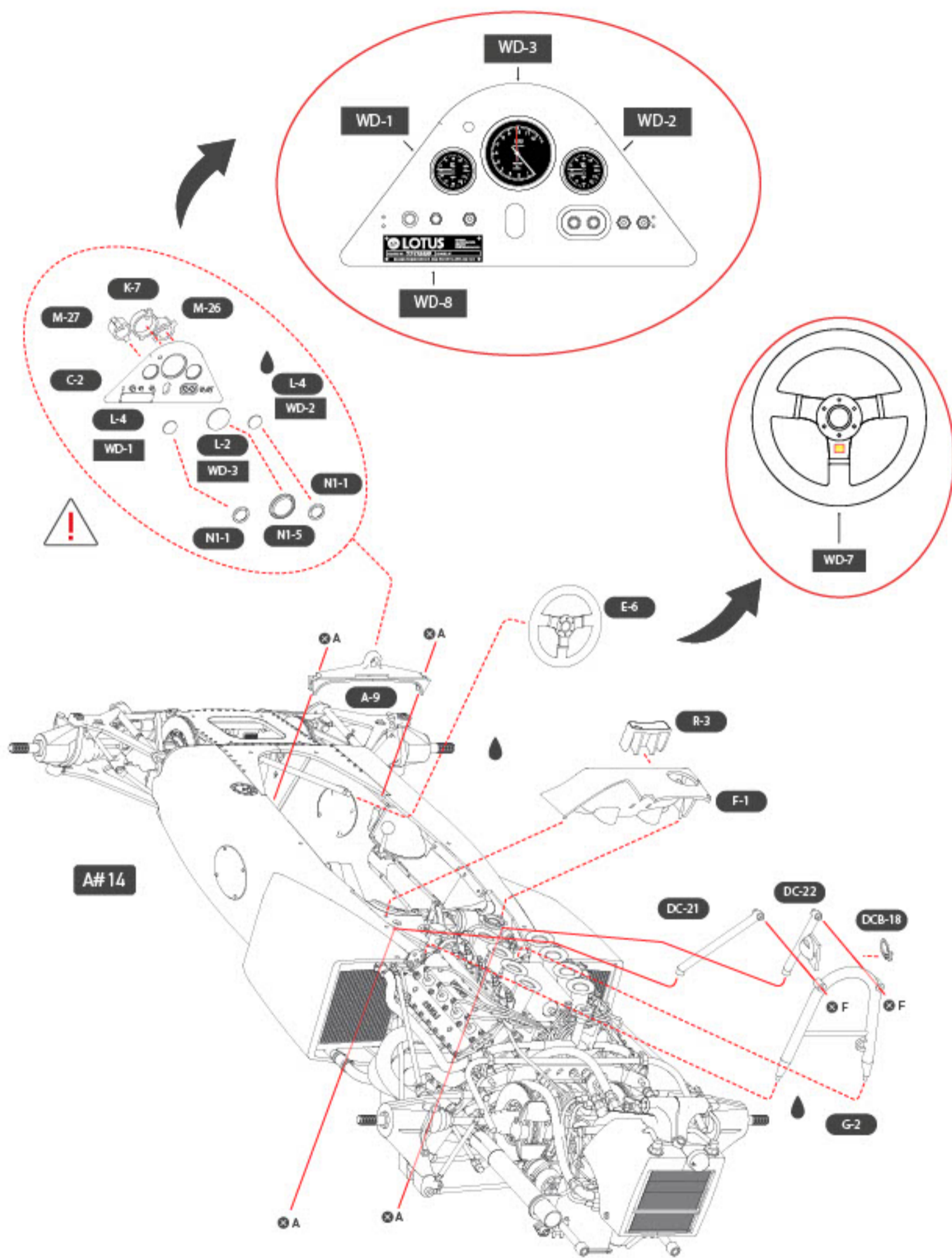

SCREW A = 4  
SCREW F = 2

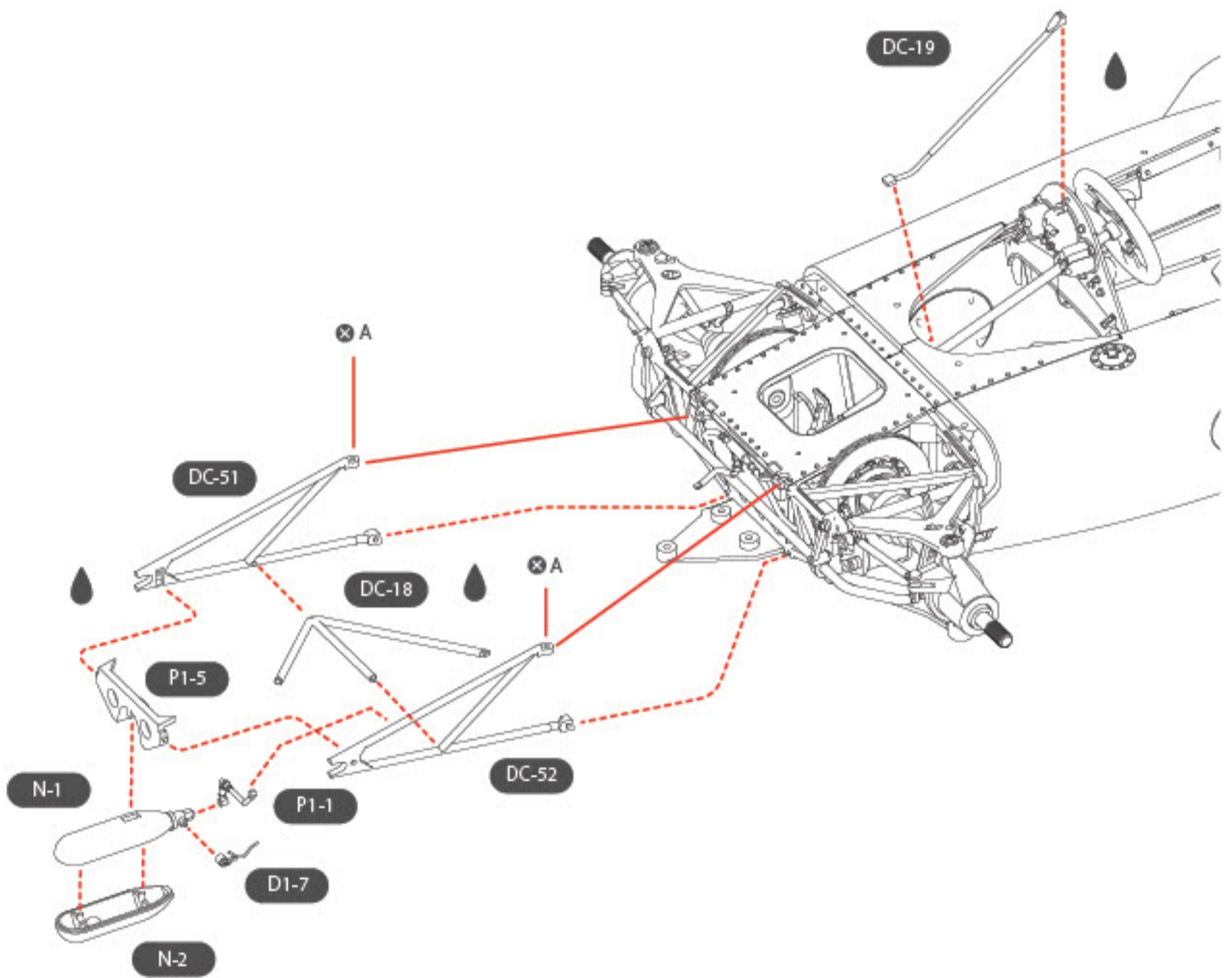

SCREW A = 2

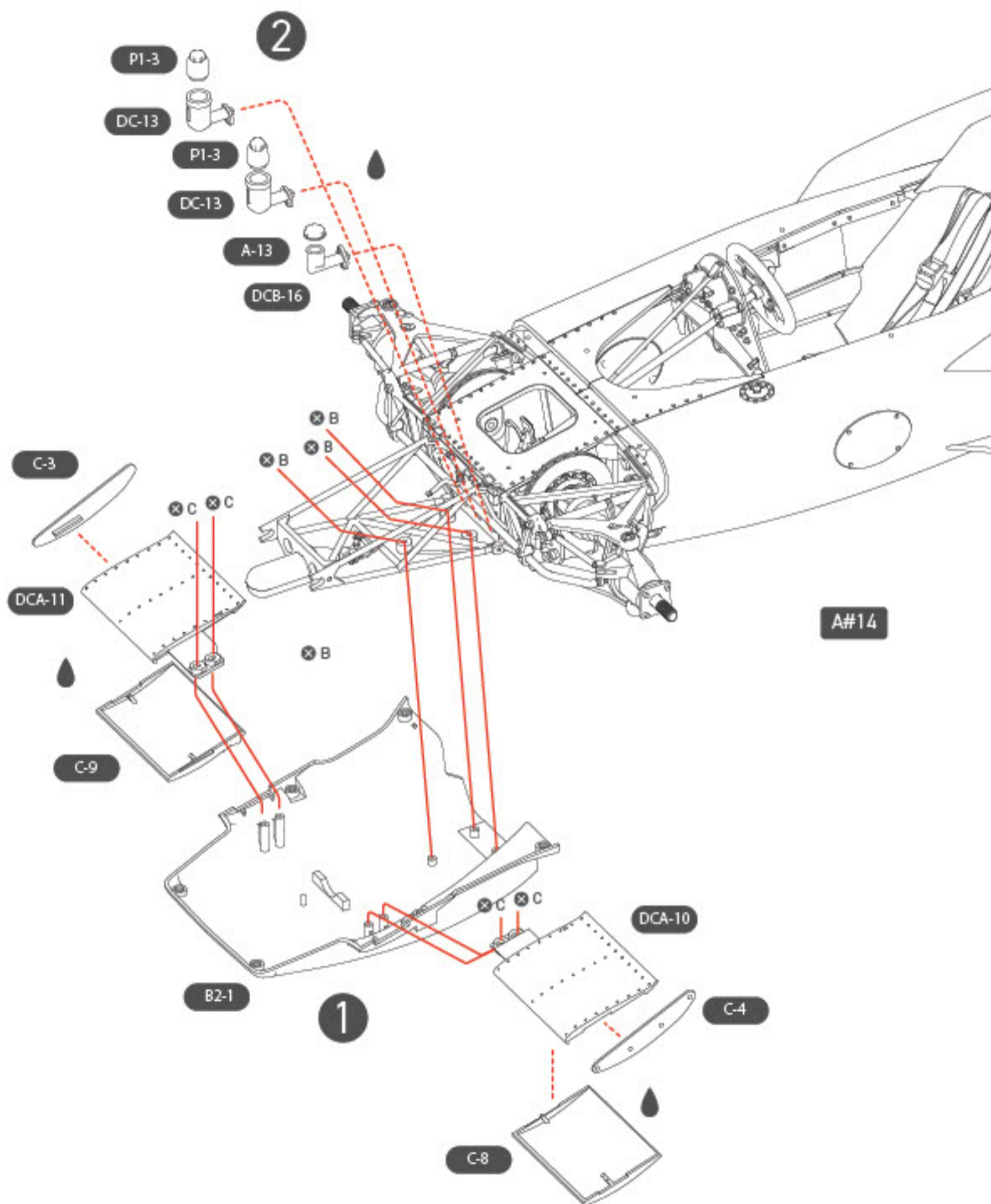

SCREW B = 3  
 SCREW C = 4



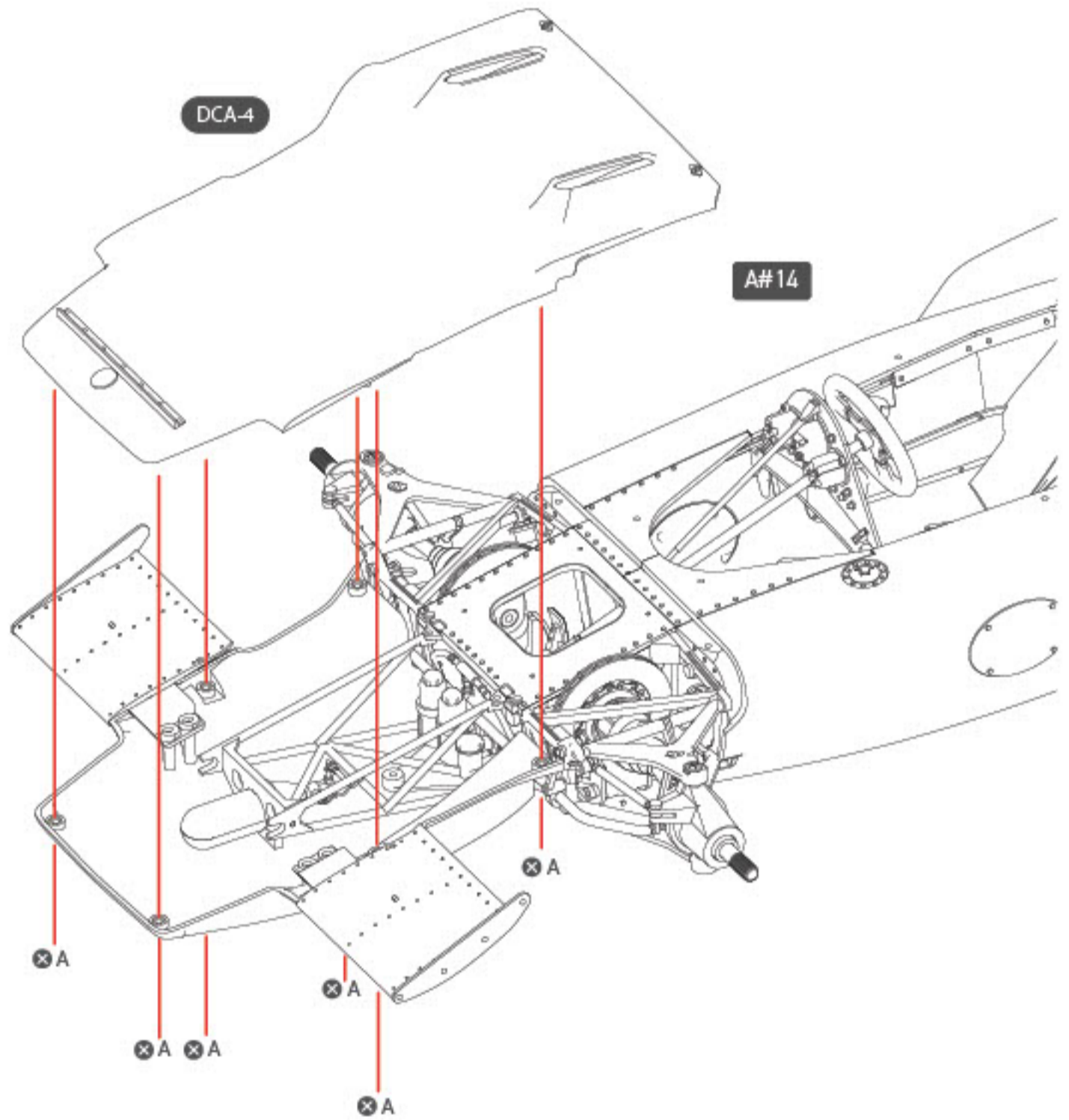

SCREW A = 6

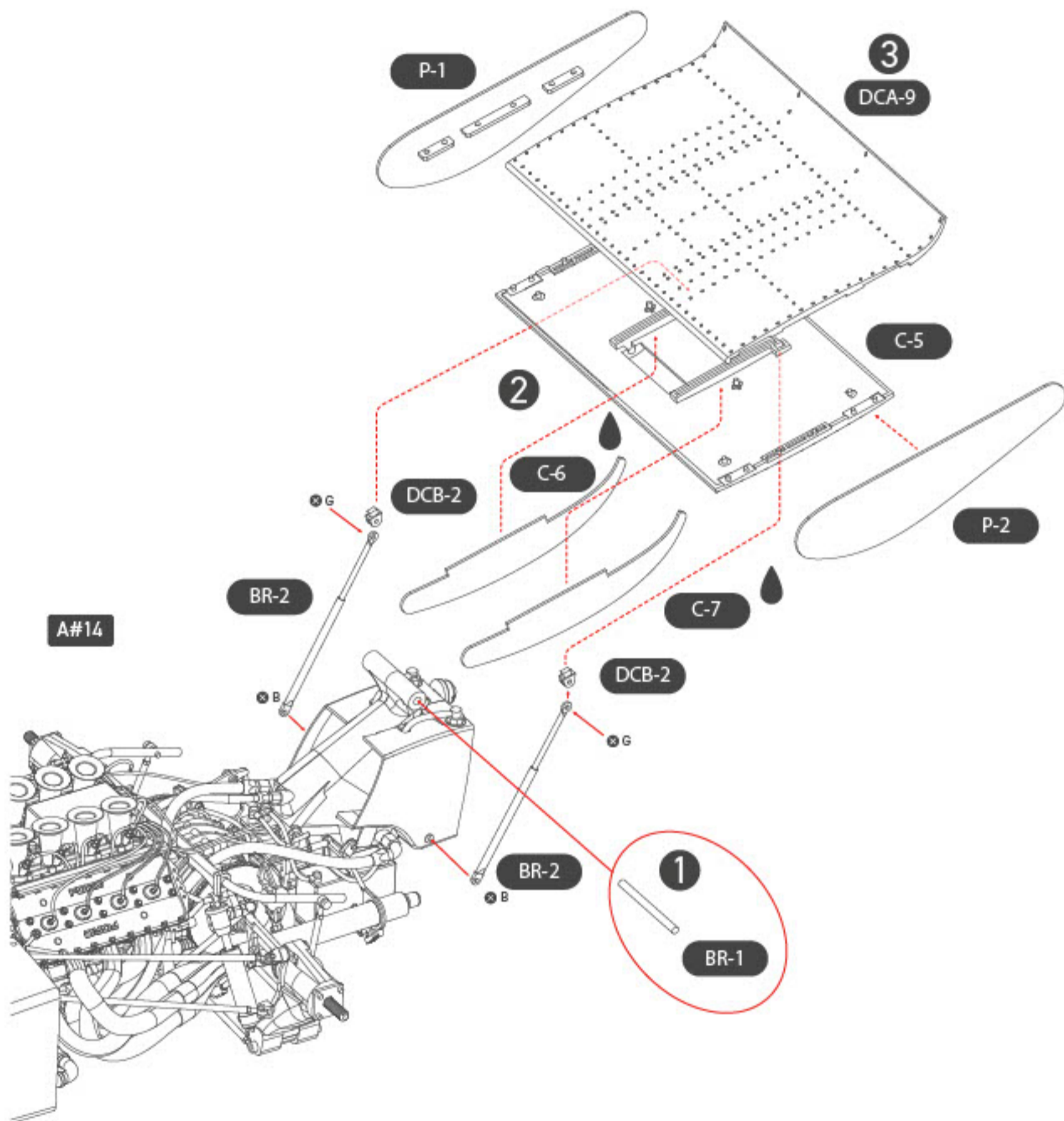

SCREW B = 2  
SCREW G = 2

